

AGI **STORM**

Seed Treater

FX Series – 2019 Model Operator's Manual



Read this manual before using product. Failure to follow instructions and safety precautions can result in serious injury, death, or property damage. Keep manual for future reference.

Part Number: 4400–90005 R3

Revised: April 2021

Original Instructions

CONTENTS

- 1. Introduction 6**
 - 1.1 Serial Number Location 6
 - 1.2 Intended Use 7
 - 1.2.1 Misuse 7
- 2. Safety..... 8**
 - 2.1 Safety Alert Symbol and Signal Words..... 8
 - 2.2 Follow Safety Instructions 8
 - 2.3 Rotating Flighting Safety 9
 - 2.4 Overhead Power Lines 9
 - 2.5 Cleated Conveyor Belt Safety..... 9
 - 2.6 Upending 9
 - 2.7 Seed Treatment Safety..... 10
 - 2.8 Rotating Parts Safety 10
 - 2.9 Work Area Safety 10
 - 2.10 Guards Safety 11
 - 2.11 Raising and Lowering the Seed Treater 11
 - 2.12 Hydraulic Winch Safety 11
 - 2.13 Hand Winch Safety 12
 - 2.14 Positioning the Seed Treater..... 12
 - 2.15 Towing the Seed Treater 12
 - 2.16 Drives and Lockout Safety..... 12
 - 2.16.1 Gas Engine Safety 13
 - 2.16.2 Electric Motor Safety..... 14
 - 2.16.3 Hydraulic Power Safety 14
 - 2.17 Tire Safety..... 15
 - 2.18 Battery Safety 15
 - 2.19 Personal Protective Equipment..... 16
 - 2.20 Safety Equipment 17
 - 2.21 Safety Decals 18
 - 2.21.1 Decal Installation/Replacement 18
 - 2.21.2 Safety Decal Locations and Details 18
- 3. Features..... 27**
 - 3.1 Main Components 27
 - 3.2 Controls 28
- 4. Preparation 29**
 - 4.1 Emergency Response Plan 29
 - 4.2 Safety Training..... 30
 - 4.3 Containment..... 30
- 5. Transport..... 31**
 - 5.1 Transport Safety 31
 - 5.2 Transport Procedure 31
- 6. Placement 34**
 - 6.1 Placement Safety..... 34
 - 6.2 Position the Seed Treater..... 34
- 7. Operation 36**

7.1 Operation Safety	36
7.2 Pre-Season Tasks	36
7.3 Conveyor Break-In	36
7.4 Treating Seed.....	37
7.4.1 Engage and Disengage Pump Hoses	37
7.4.2 Create a Job.....	39
7.4.3 Calibrate the Pumps.....	40
7.4.4 Operate the Treater & Treat Seed	41
7.4.5 Update the Calibration.....	42
7.5 Emergency Stop.....	42
7.6 Restarting a Full Seed Treater	42
7.7 General Clean-Out Procedure	42
7.8 Chemical Spill Cleanup	43
7.9 Storage.....	43
8. Software Screens	45
8.1 Electronic Controls	45
8.2 View and Configure Current Date and Time.....	45
8.3 View Software Version	46
8.4 View and Configure Pump Setup	47
8.5 View and Configure Advanced Pump Setup	48
8.6 View and Configure Conveyor Options.....	48
8.7 Viewing Configured Jobs	49
8.8 Deleting a Job	50
8.9 Viewing Job Parameters.....	50
8.10 Viewing Treating History (All Jobs)	52
8.11 Viewing Treating History (Specific Job).....	53
8.12 Calibrate a One Pump Job.....	54
8.13 Calibrate a Two Pump Job.....	56
8.14 Calibration Results.....	63
8.15 Calibration Successful.....	64
8.16 Overriding the Pump Speed Setpoint	65
8.17 Viewing Amount of Seed Treated While Operating (Job Specific).....	66
8.18 Viewing Amount of Treatment Used While Operating (Job Specific)	66
8.19 Seed Flow Correction	67
8.20 Flush Out	69
8.21 View Lifetime Total Use	70
8.22 View Diagnostics.....	71
8.23 Alarms.....	72
9. Maintenance	75
9.1 Maintenance Safety	75
9.2 Maintenance Schedule	75
9.3 Visually Inspect the Seed Treater.....	77
9.4 Grease the Bearings	77
9.5 Check the Gearbox Oil.....	78
9.6 Change the Gearbox Oil	78
9.7 Clean and Coat the Calibration Cylinders	78
9.8 Clean the Mixing Boot and Chemical Hoses	79
9.9 Check the Chemical Pump Rollers	80
9.10 Clean the Filter Strainers.....	80

9.11 Fill the System with Antifreeze 81

9.12 Drain Antifreeze from the System 81

9.13 Clean the Conveyor Belt..... 82

9.14 Check and Maintain the Containment System 82

9.15 Advanced Mixer Clean-Out 83

9.16 Check and Replace the Pump’s Chemical Hoses 83

 9.16.1 Pump Tubing Break-In..... 84

9.17 Inspect/Replace the Conveyor Rollers and Bearings..... 84

9.18 Tension the Conveyor Belt..... 85

9.19 Align the Conveyor Belt..... 86

 9.19.1 Adjust the Rollers 87

9.20 Tension the Drive Belts 88

9.21 Align the Drive Belts..... 88

9.22 Replace the Drive Belts 89

9.23 Clean and Wash the Equipment 89

9.24 Inspect Belt Lacing..... 89

9.25 Replace the Belt Lacing 89

9.26 Replace the Conveyor Belt..... 90

9.27 Inspect and Service the Hand Winch and Lift Cable..... 91

9.28 Inspect and Service the Hydraulic Winch and Lift Cable 92

9.29 Adjust the Mover Kit Ram and Travel Speed..... 92

9.30 Pinion Gear Adjustment 93

9.31 Change the Hydraulic Oil..... 94

9.32 Remove / Replace the Shear Bolt 94

10. Troubleshooting..... 96

11. Appendix 104

 11.1 Test Weight Procedure..... 104

 11.2 Updating System Software..... 105

 11.2.1 Treating History & Job Information 106

 11.2.2 Formatting a USB 106

 11.2.3 Downloading Software..... 106

 11.2.4 Installing Software..... 107

12. Specifications 108

13. STORM Warranty..... 109

1. Introduction

Thank you for your purchase. Follow the instructions in this manual for safe use of this seed treater. Following proper operation and maintenance will help to keep the seed treater running in optimal condition.

Keep this manual handy for frequent reference and to review with new personnel. A sign-off form is provided on the inside front cover for your convenience. If any information in this manual is not understood or if you need additional information, please contact AGI or your representative for assistance.

This manual should be regarded as part of the equipment.

1.1. Serial Number Location

The serial number location for your seed treater is shown in the figure below. Have the serial number ready when ordering parts or requesting service or other information. Record information in the table below for easy reference.

Model Number	
Serial Number	
Date Received	

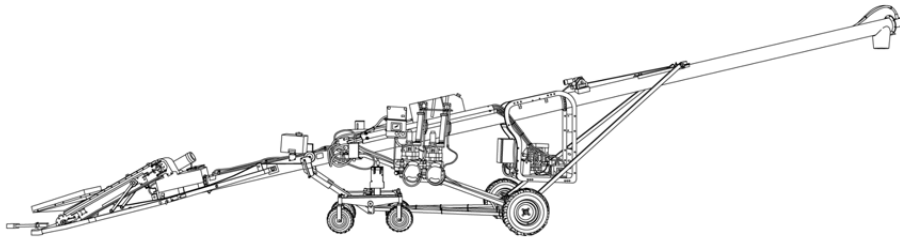

1.2. Intended Use

The seed treater is intended for use as listed below and described throughout this manual. Use in any other way is considered contrary to the intended use and is not covered by the warranty.

Intended use for the seed treater:

- seed types as detailed on the system Operation Screen.
- temperatures warmer than 32°F (0°C).
- a suitable hopper bin or truck hopper.

1.2.1 Misuse

Do not install/use the seed treater for/with:

- lifting or using as a hoist or crane.
- any purpose other than treating seed.
- treating oilseeds such as canola.
- normal loading or unloading of grain.

2. Safety

2.1. Safety Alert Symbol and Signal Words



This safety alert symbol indicates important safety messages in this manual. When you see this symbol, be alert to the possibility of injury or death, carefully read the message that follows, and inform others.

Signal Words: Note the use of the signal words **DANGER**, **WARNING**, **CAUTION**, and **NOTICE** with the safety messages. The appropriate signal word for each message has been selected using the definitions below as a guideline.



Indicates an imminently hazardous situation that, if not avoided, will result in serious injury or death.



Indicates a hazardous situation that, if not avoided, could result in serious injury or death.



Indicates a hazardous situation that, if not avoided, may result in minor or moderate injury.



Indicates a potentially hazardous situation that, if not avoided, may result in property damage.

2.2. Follow Safety Instructions

Read and understand all safety instructions, safety decals, and manuals and follow them when operating or maintaining the equipment.

- Owners must give instructions and review the information initially and annually with all personnel before allowing them in the work area. Untrained users/operators expose themselves and bystanders to possible serious injury or death.
- Use for intended purposes only.
- Do not modify the seed treater in any way without written permission from the manufacturer and is not covered by the warranty.
- Follow a health and safety program for your worksite. Contact your local occupational health and safety organization for information.
- Follow applicable local codes and regulations.



2.3. Rotating Flighting Safety

DANGER

- KEEP AWAY from rotating flighting.
- DO NOT remove or modify flighting guards, doors, or covers. Keep in good working order. Have replaced if damaged.
- DO NOT operate the seed treater without all guards, doors, and covers in place.
- NEVER touch the flighting. Use a stick or other tool to remove an obstruction or clean out.
- Shut off and lock out power to adjust, service, or clean.



2.4. Overhead Power Lines

DANGER

- When operating or moving, keep seed treater away from overhead power lines and devices.
- The seed treater is not insulated.
- Electrocutation can occur without direct contact.



2.5. Cleated Conveyor Belt Safety

WARNING

- KEEP HANDS AWAY from moving cleated conveyor belt.
- DO NOT remove or modify guards, doors, or covers. Keep in place and in good working order. Have replaced if damaged.
- DO NOT operate the conveyor without all guards, doors, and covers in place.
- Shut off and lock out power to adjust, service, or clean.



2.6. Upending

WARNING

- Anchor intake end and/or support discharge end to prevent upending.
- Intake end must always have downward weight. Do not release until attached to tow bar or resting on ground.
- Do not raise intake end above tow bar height.
- Empty the seed treater and fully lower before moving.

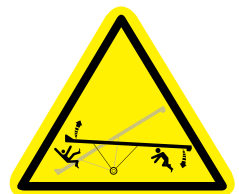

2.7. Seed Treatment Safety

Hazards associated with handling, sorting, mixing and storage of treated seed and seed treatments can be minimized by following the safety precautions listed below. The below are guidelines only and vary based on the type of seed treatment being used. Consult the seed treatment information sheets for full details.

WARNING

- Before treating seed, follow and have a written plan in place to manage volumes of contaminated water and/or other liquids used in the cleaning/flushing of the seed treating equipment.
- Use personal protective equipment as described on the seed treatment product label.
- Use the seed treater only outdoors, do not use inside a building or structure.
- Thoroughly clean the seed treater after use. Some seed treatments are corrosive and others may plug the equipment. Do not run contaminated water into a stream, public sewer, or in a location where it could contaminate the groundwater or come into contact with people or animals.

2.8. Rotating Parts Safety

WARNING

- Keep body, hair, and clothing away from rotating pulleys, belts, chains, and sprockets.
- Do not operate with any guard removed or modified. Keep guards in good working order.
- Shut off and lock out power source before inspecting or servicing machine.



2.9. Work Area Safety

- Have another trained person nearby who can shut down the seed treater in case of accident.
- The work area should be kept clear of bystanders, including children.
- Keep the work area clean and free of debris.
- Keep the required personal protective equipment (PPE) and emergency equipment in its designated location.
- Never smoke, drink, or eat in the seed treatment area
- Keep lighting in place where seed treatment activities are being undertaken during hours of the day when natural light is not present.
- Have an emergency response plan and keep a copy of the plan in the product manual holder.
- Post a sign identifying the name of the company, applicable management phone numbers, and emergency response numbers.

2.10. Guards Safety

- ⚠ WARNING**
- Keep guards in place. Do not operate with guard removed.
 - Do not walk on, step on, or damage guards.
 - Lock out power before removing a guard.
 - Ensure all guards are replaced after performing maintenance.

2.11. Raising and Lowering the Seed Treater

- ⚠ WARNING**
- Before raising/lowering/moving/adjusting the seed treater, make sure the area around the seed treater is clear of obstructions and/or untrained personnel. Never allow anyone to stand on or beneath the seed treater when it is being placed.
 - Lower the seed treater to its lowest position when not in use.
 - Empty the seed treater before raising or lowering.
 - Do not get on or beneath the seed treater when raising or lowering.
 - Raise and lower seed treater on reasonably level ground only.
 - Never attempt to increase height of the seed treater by positioning wheels on lumber, blocks, or by any other means. To do so will result in damage to seed treater and/or serious injury.
 - Do not raise the seed treater in high winds.

2.12. Hydraulic Winch Safety

- ⚠ WARNING** When Equipped:
- Keep away from rotating cable drum and winch cable. Do not touch or grab cable while winch is being operated or use hands to guide the cable.
 - Inspect cable and cable clamps before using hydraulic winch. Replace cable if frayed or damaged. Tighten cable clamps if necessary.
 - Check the cable anchor on the winch drum is tight.
 - Confirm hydraulic hoses are in good condition.
 - Do not continue to supply power to hydraulic winch after the seed treater has reached full up position.
 - Do not disconnect hydraulic quick couplers when lines are pressurized.
 - Make sure lift cable is seated in cable pulley.
 - Always keep a minimum of 3 cable wraps on the cable drum.

2.13. Hand Winch Safety

WARNING When Equipped:

- Inspect lift cable before using. Replace if frayed or damaged. Make sure lift cable is seated properly in cable sheaves and cable clamps are secure.
- Tighten brake lock by turning winch handle clockwise at least two clicks after lowering the seed treater.
- Lower the seed treater fully before towing, then rotate winch handle until cable has light tension.
- Do not lubricate winch brake discs.

2.14. Positioning the Seed Treater

- ### **WARNING**
- Transport and place equipment on reasonably level ground when raising, lowering, positioning, or operating.
 - Move the seed treater into position slowly. Do not unhitch and attempt to move by hand.
 - Chock wheels and anchor intake end after placement.

2.15. Towing the Seed Treater

- ### **WARNING**
- Check with local authorities regarding transport on public roads. Obey all applicable laws and regulations.
 - Always travel at a safe speed, the seed treater can be transported up to a maximum of 20 mph (32 km/h). Reduce speed on rough surfaces. Use caution when turning corners or meeting traffic.
 - Reduce speed on rough surfaces.
 - Do not transport on slopes greater than 20°.
 - Use caution when turning corners or meeting traffic.
 - Do not allow riders on the seed treater or towing vehicle during transport.
 - Always attach safety chain(s) for transport on roadways.
 - Place the seed treater in the transport position before moving on roads.

2.16. Drives and Lockout Safety

Inspect the power source(s) before using and know how to shut down in an emergency. Whenever you service or adjust your equipment, make sure you shut down the power source and follow lockout and tagout procedures to prevent inadvertent start-up and hazardous energy release. Know the procedure(s) that applies to your equipment from the following power source(s). Ensure that only 1 key exists for each assigned lock, and that you are the only one that holds that key. Ensure that all personnel are clear before turning on power to equipment.



2.16.1 Gas Engine Safety

WARNING Power Source

- Keep guards in place and secure.
- Properly ventilate surrounding area.
- Never fill the fuel tank with the engine running, while smoking, or near an open flame. Always shut down and allow engine to cool before filling with fuel.
- Never overfill the tank or spill fuel. If fuel is spilled, clean it up immediately.
- Be sure to use the correct type and grade of fuel. Ground the fuel funnel or nozzle against the filler neck to prevent sparks that could ignite fuel vapors.
- Be sure to replace the fuel fill cap when you are done.

Lockout

- For engines with an electric start, remove the ignition key, the spark plug wire, or the spark plug.
- For engines with a rope or crank start, remove the spark plug wire or the spark plug.



2.16.2 Electric Motor Safety

WARNING Power Source

- Electric motors and controls shall be installed and serviced by a qualified electrician and must meet all local codes and standards.
- Guards must be in place and secure.
- Ensure electrical wiring and cords remain in good condition; replace if necessary.

2.16.3 Hydraulic Power Safety

WARNING Power Source

- Refer to the rules and regulations applicable to the power source operating your hydraulic drive.
- Do not connect or disconnect hydraulic lines while system is under pressure.
- Keep all hydraulic lines away from moving parts and pinch points.
- Escaping hydraulic fluid under pressure will cause serious injury if it penetrates the skin surface (serious infection or toxic reaction can develop). See a doctor immediately if injured.
- Use metal or wood as a backstop when searching for hydraulic leaks and wear proper hand and eye protection.
- Check all hydraulic components are tight and in good condition. Replace any worn, cut, abraded, flattened, or crimped hoses.
- Clean the connections before connecting to equipment.
- Do not attempt any makeshift repairs to the hydraulic fittings or hoses with tape, clamps, or adhesive. The hydraulic system operates under extremely high pressure; such repairs will fail suddenly and create a hazardous and unsafe condition.

Lockout

- Always place all hydraulic controls in neutral and relieve system pressure before disconnecting or working on hydraulic system.



2.17. Tire Safety

⚠️ WARNING

Failure to follow proper procedures when mounting a tire on a wheel or rim can produce an explosion that may result in serious injury or death.



- DO NOT attempt to mount a tire unless you have the proper equipment and experience to do the job.
- Have a qualified tire dealer or repair service perform required tire maintenance.
- When replacing worn tires, make sure they meet the original tire specifications. Never undersize the replacement tire.
- DO NOT weld to the tire rim with the tire mounted on the rim. This action may cause an explosion which could result in serious injury or death.
- Inflate tires to the manufacturer's recommended pressure.
- Tires should not be operated at speeds higher than their rated speed.
- Keep wheel lug nuts tightened to manufacturer's recommendations.
- Never reinflate a tire that has been run flat or seriously under-inflated without removing the tire from the wheel. Have the tire and wheel closely inspected for damage before remounting.

2.18. Battery Safety

⚠️ WARNING

- Wear safety glasses and protective gloves when working near batteries.
- Make certain the battery or terminal covers are in place and in good working order.
- Keep all sparks and flames away from batteries; gas given off by electrolyte is explosive.
- Avoid contact with battery electrolyte. Wash off any spilled electrolyte immediately.
- Do not tip batteries more than 45° to avoid electrolyte loss.
- To avoid injury from sparks or short circuits, disconnect battery ground cable before servicing any part of an electrical system.



2.19. Personal Protective Equipment

The following Personal Protective Equipment (PPE) should be worn when operating or maintaining the equipment.

Safety Goggles

- Wear safety goggles at all times to protect eyes from chemicals.

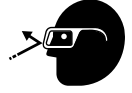

Coveralls

- Wear coveralls to protect skin.



Hard Hat

- Wear a hard hat to help protect your head.



Rubber Boots

- Wear rubber boots to prevent contact with chemicals.



Chemically Resistant Gloves

- Wear chemically resistant gloves to protect your hands from chemicals.



Respirator

- Wear a respirator with chemical cartridges to prevent breathing potentially harmful vapors.



Hearing Protection

- Wear ear protection to prevent hearing damage.



2.20. Safety Equipment

The following safety equipment should be kept on site.

Fire Extinguisher

- Provide a fire extinguisher for use in case of an accident. Store in a highly visible and accessible place.



First-Aid Kit

- Have a properly-stocked first-aid kit available for use should the need arise, and know how to use it.



Eyewash Kit

- Keep a portable eye wash kit available or make sure a permanent eyewash station is available should the need arise to flush materials from the eyes. Review instructions for use before working with the seed treater.



Salvage Container

- Keep a sealable salvage container on site, such as a spill containment pallet.



Absorbent Materials

- Keep granular absorbent materials on hand to clean up any chemical spills.



Aluminum Shovel and Broom

- Keep an aluminum shovel and broom for cleanup of spilled materials.

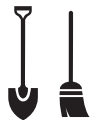

2.21. Safety Decals

- Keep safety decals clean and legible at all times.
- Replace safety decals that are missing or have become illegible. See decal location figures that follow.
- Replaced parts must display the same decal(s) as the original part.
- Replacement safety decals are available **free of charge** from your distributor, dealer, or factory as applicable.

2.21.1 Decal Installation/Replacement

1. Decal area must be clean and dry, with a temperature above 50°F (10°C).
2. Decide on the exact position before you remove the backing paper.
3. Align the decal over the specified area and carefully press the small portion with the exposed sticky backing in place.
4. Slowly peel back the remaining paper and carefully smooth the remaining portion of the decal in place.
5. Small air pockets can be pierced with a pin and smoothed out using the decal backing paper.

2.21.2 Safety Decal Locations and Details

Replicas of the safety decals that are attached to the seed treater and their messages are shown in the figure(s) that follow. Safe operation and use of the seed treater requires that you familiarize yourself with the various safety decals and the areas or particular functions that the decals apply to, as well as the safety precautions that must be taken to avoid serious injury, death, or damage.

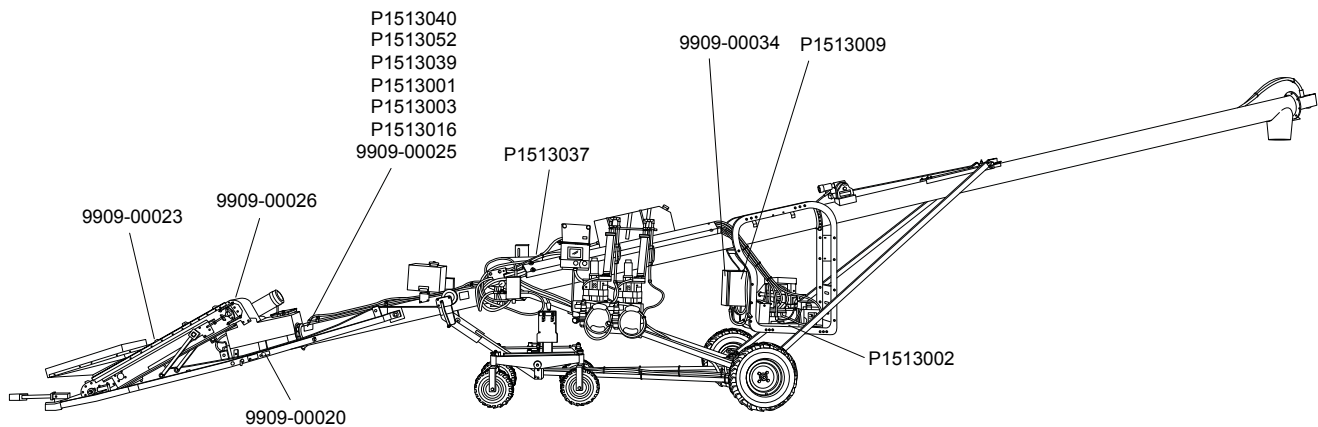

Table 1. Safety Decals



Part Number	Description
P1513016	<div style="border: 1px solid black; padding: 10px;"> <div style="background-color: red; color: white; text-align: center; padding: 5px;">  DANGER </div> <div style="display: flex; justify-content: space-around; align-items: center; margin-top: 10px;">   </div> <div style="text-align: center; margin-top: 10px;"> <p>ROTATING FLIGHTING HAZARD</p> <p>To prevent death or serious injury:</p> <ul style="list-style-type: none"> • KEEP AWAY from rotating auger flighting. • DO NOT remove or modify auger flighting guards, doors, or covers. Keep in good working order. Have replaced if damaged. • DO NOT operate the auger without all guards, doors, and covers in place. • NEVER touch the auger flighting. Use a stick or other tool to remove an obstruction or clean out. • Shut off and lock out power to adjust, service, or clean. </div> </div>

Table 1 Safety Decals (continued)



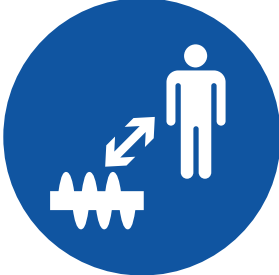

Part Number	Description
P1513003	<div style="border: 1px solid black; padding: 10px;"> <div style="background-color: red; color: white; text-align: center; padding: 5px;">  DANGER </div> <div style="display: flex; justify-content: space-around; align-items: center; margin-top: 10px;">   </div> <div style="text-align: center; margin-top: 10px;"> <p>ELECTROCUTION HAZARD</p> <p>To prevent death or serious injury:</p> <ul style="list-style-type: none"> • When operating or moving, keep equipment away from overhead power lines and devices. • Fully lower equipment before moving. <p>This equipment is not insulated.</p> <p>Electrocution can occur without direct contact.</p> </div> </div>
P1513036	<div style="border: 1px solid black; padding: 10px;"> <div style="display: flex; justify-content: space-between; align-items: center; margin-bottom: 10px;">  <div style="background-color: orange; color: black; text-align: center; padding: 5px;">  WARNING </div> </div> <div style="margin-bottom: 10px;"> <p>HIGH PRESSURE FLUID HAZARD</p> <p>Hydraulic fluid can cause serious injury if it penetrates the skin. If it does, see a doctor immediately.</p> <ul style="list-style-type: none"> • Relieve system pressure before repairing, adjusting or disconnecting. • Wear proper hand and eye protection when searching for leaks. Use wood or cardboard instead of hands. </div> <div style="display: flex; justify-content: space-between; align-items: center;">  </div> </div>

Table 1 Safety Decals (continued)

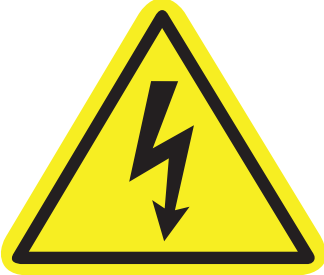
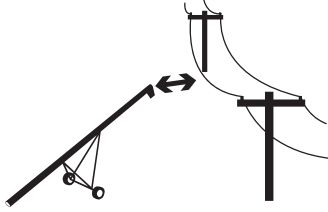

Part Number	Description
P1513001	<div style="border: 1px solid black; padding: 10px;"> <div style="background-color: #f4a460; text-align: center; padding: 5px;">  WARNING </div> <div style="display: flex; justify-content: space-around; align-items: center; margin-top: 10px;"> <div style="text-align: center;">  </div> <div style="text-align: center;">  </div> </div> <p style="margin-top: 10px;">To prevent serious injury or death:</p> <ul style="list-style-type: none"> • Read and understand the manual before assembling, operating, or maintaining the equipment. • Only trained personnel may assemble, operate, or maintain the equipment. • Children and untrained personnel must be kept outside of the work area. • Do not modify the equipment. Keep in good working order. • If the manual, guards, or decals are missing or damaged, contact factory or representative for free replacements. • Lock out power before performing maintenance. • To prevent equipment collapse or upending, support equipment tube while disassembling certain components. • Follow grain storage structure manufacturer's warnings when loading and unloading. • Electric motors must be grounded. Disconnect power before resetting overloads. </div>

Table 1 Safety Decals (continued)





Part Number	Description
P1513002	<div style="border: 2px solid black; padding: 10px;"> <div style="background-color: #f4a460; text-align: center; padding: 5px; border: 1px solid black;">  WARNING </div> <div style="display: flex; justify-content: space-around; align-items: center; margin-top: 10px;">   </div> <div style="text-align: center; margin-top: 10px;"> <p>ENTANGLEMENT HAZARD</p> <p>To prevent serious injury or death:</p> <ul style="list-style-type: none"> Keep body, hair, and clothing away from rotating pulleys, belts, chains, and sprockets. Do not operate with any guard removed or modified. Keep guards in good working order. Shut off and lock out power source before inspecting or servicing machine. </div> </div>
P1513037	<div style="border: 2px solid black; padding: 10px;"> <div style="background-color: #f4a460; text-align: center; padding: 5px; border: 1px solid black;">  WARNING </div> <div style="text-align: center; margin-top: 10px;"> <p>TRANSPORT HAZARD</p> <p>To prevent serious injury or death:</p> <ul style="list-style-type: none"> Securely attach equipment to vehicle with correct pin and safety chains. Use a tow vehicle to move equipment. </div> </div>

Table 1 Safety Decals (continued)





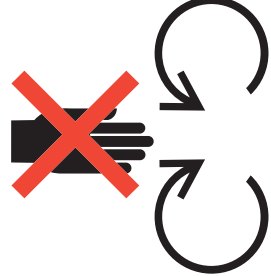

Part Number	Description
P1513009	<div style="display: flex; align-items: center;">  <div style="margin-left: 10px;"> <p>⚠ WARNING</p> <p>ELECTROCUTION HAZARD</p> <p>To prevent serious injury or death:</p> <ul style="list-style-type: none"> • Only qualified personnel should service electrical components. • Disconnect and lockout power before inspecting or servicing unit. • Keep electrical components in good repair. </div> </div> <div style="margin-top: 10px;">  </div>
P1513040	<div style="border: 1px solid black; padding: 5px;"> <p style="text-align: center;">⚠ WARNING</p> <p style="text-align: center;">TRANSPORT HAZARD</p> <p>To prevent serious injury or equipment damage, before towing:</p> <ul style="list-style-type: none"> • Lift up wheel frame completely and secure with safety chain. • Pull handle to disengage drive wheel motors. </div>
9909–00020	<div style="display: flex; align-items: center;">  <div style="margin-left: 10px;"> <p>⚠ WARNING</p> <p>CRUSH HAZARD</p> <p>To prevent serious injury, insert pin before clean out of hopper.</p> </div> </div> <div style="margin-top: 10px;">  </div>
9909–00023	<div style="display: flex; align-items: center;">  <div style="margin-left: 10px;"> <p>⚠ WARNING</p> <p>BELT CRUSH HAZARD</p> <p>To prevent serious injury:</p> <ul style="list-style-type: none"> • KEEP HANDS AWAY from moving cleated conveyor belt. • DO NOT remove or modify guards, doors, or covers. Keep in place and in good working order. Have replaced if damaged. • DO NOT operate the conveyor without all guards, doors, and covers in place. • Shut off and lock out power to adjust, service, or clean. </div> </div> <div style="margin-top: 10px;">  </div>

Table 1 Safety Decals (continued)



Part Number	Description
9909-00025	<div style="border: 2px solid black; padding: 10px;"> <div style="background-color: #f4a460; text-align: center; padding: 5px; border: 1px solid black;">  WARNING </div> <div style="display: flex; justify-content: space-around; align-items: center; padding: 10px 0;"> <div style="text-align: center;">  </div> <div style="text-align: center;">  </div> </div> <div style="text-align: center; padding: 10px 0;"> <p>UPENDING HAZARD</p> <p>To prevent death or serious injury:</p> <ul style="list-style-type: none"> Anchor intake end and/or support discharge end to prevent upending. Intake end must always have downward weight. Do not release until attached to tow bar or resting on ground. Do not raise intake end above tow bar height. Empty tube and fully lower before moving. </div> </div>
9909-00026	<div style="border: 2px solid black; padding: 10px;"> <div style="background-color: #f4a460; text-align: center; padding: 5px; border: 1px solid black;">  WARNING </div> <div style="padding: 10px 0;"> <p>Keep guards in place when operating.</p> </div> </div>

Table 1 Safety Decals (continued)

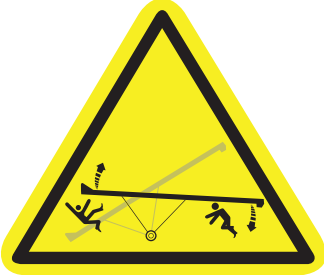

Part Number	Description
P1513039	<div style="border: 1px solid black; padding: 10px;"> <div style="background-color: yellow; text-align: center; padding: 5px;">  CAUTION </div> <p>For proper raising and lowering of equipment:</p> <ul style="list-style-type: none"> • After lowering equipment, always tighten brake lock by turning winch handle clockwise at least two clicks. • Rotate winch handle until cable has light tension, when in towing position. • Do not lubricate winch brake discs. • Inspect lift cable periodically; replace if damaged. • Inspect cable clamps periodically; tighten if necessary. </div>
9909-00034	<div style="border: 1px solid black; padding: 10px;"> <div style="background-color: blue; color: white; text-align: center; padding: 5px;"> NOTICE </div> <div style="text-align: center; margin: 10px 0;">  </div> <p>Do not weld anywhere on this equipment.</p> <p>If welding is required for repair, remove the component to be welded. If removing the component is not possible, call 1-855-662-6609 for STORM support.</p> <p>Failure to follow will result in damage to the electrical components.</p> </div>

Table 1 Safety Decals (continued)

Part Number	Description
P1513052	 <p>NOTICE</p> <p>To prevent damage, wheels must be free to move when raising or lowering equipment.</p> <p>When equipment is positioned, chock all wheels.</p>

3. Features

Read this section to familiarize yourself with the basic component names and functions of the seed treater.

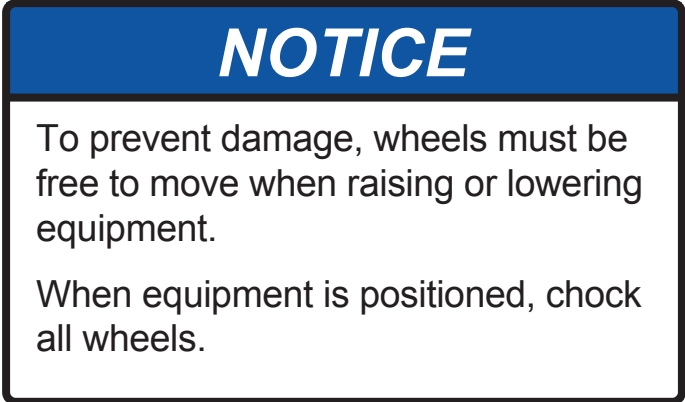
3.1. Main Components

The figure and table below covers the main components of the seed treater.

Figure 1. Main Components

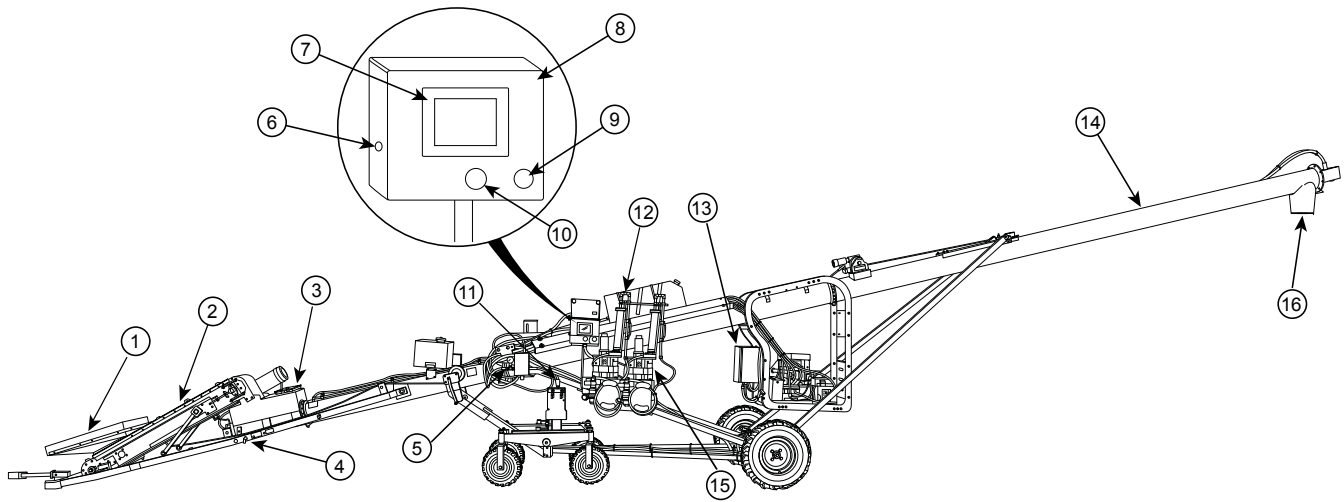

Table 2. Main Components

Item	Description	Item	Description
1	Conveyor Intake	9	Emergency Stop / Pause Button
2	Conveyor	10	Alarm
3	Mixer Boot	11	Controls (positioning)
4	Transport Lock	12	Calibration Cylinders
5	Mixer Valve	13	Control Box
6	USB Port (for updating software and exporting data)	14	Mixer
7	Operation Screen	15	Seed Treatment Metering Pumps
8	Control Panel	16	Discharge Spout

3.2. Controls

The STORM mixer section has the following controls:

Mechanical Controls

- Engine throttle with variable RPM.
- Mover kit controls move/steer the unit and raise/lower the mixer tube.
- Conveyor winch to raise and lower the conveyor.
- Calibration Valves.
- Valve to operate the flighting.

Touch-Screen Controls

- Configure, calibrate, run and stop jobs.
- View job information and system status.
- Prepare pumps and conveyor for treating.
- Control pumps and conveyor for clean up. On the top of the control box is a physical pause button. Pressing this button stops the pumps and conveyor and functions as an emergency stop.

4. Preparation

4.1. Emergency Response Plan

A response plan must be developed before using the seed treater the first time to be prepared in the event of an emergency. Keep a copy of the plan in the product manual holder. This section provides guidance on developing your emergency response plan.

When developing an emergency response plan, include the following:

Potential Emergencies

Emergencies that could occur are:

- Safety: cutting, severing, crushing, entanglement, electrocution, hydraulic fluid injection, chemical contact/irritation/inhalation, burns.
- Environmental: site contamination, chemical spills, seed spills, treated seed spill.

Training and Procedures for Emergency Response

When training employees on an emergency response plan, know the following:

- Collect employee information including contact numbers, next-of-kin, and medical care. Keep this information in the manual container.
- Know who to call, information about the employee, and the nature of the emergency.
- Complete emergency response training prior to the start of each treating season.
- Test employees to be sure they know what to do in an emergency situation.
- Keep records of training and trained employees.
- Know the location and use of common emergency equipment.
- Know the potential emergencies (see above) that could occur, and how to respond.
- A worker at the site should be trained in First Aid and CPR.
- Know how to use the provided safety equipment.
- Know how to contain and properly clean up a small chemical spill to minimize or prevent environmental damage.
- Review and understand applicable product labels and Material Safety Data Sheets (MSDS) for chemicals that are being used.

4.2. Safety Training

After reading this manual and completing training, an operator must be able to:

	<p>Explain the established procedures for the use and care of emergency and safety equipment including:</p> <ul style="list-style-type: none"> • Personal Protective Equipment (PPE) • First aid kits • Eyewash stations • Fire extinguishers
	<p>Explain procedures for:</p> <ul style="list-style-type: none"> • Safe and effective application of seed treatment products • Care, operation, and cleaning of seed treatment equipment • Labelling of treated seed
	<p>Describe spill cleanup procedures and know where the emergency supplies and equipment are located.</p>
	<p>Describe the components of the Emergency Response Plan, including:</p> <ul style="list-style-type: none"> • safety or environmental hazards that could occur • how to respond in the event of an emergency

4.3. Containment

The STORM seed treater is not equipped to contain spills.

5. Transport



Before continuing, ensure you have completely read and understood this manual's Safety section, in addition to the safety information in the section(s) below.

5.1. Transport Safety

WARNING

- Check with local authorities regarding transport on public roads. Obey all applicable laws and regulations.
- Always travel at a safe speed, never exceeding 20 mph (32 km/h). Reduce speed on rough surfaces. Use caution when turning corners or meeting traffic.
- Yield to other drivers and allow faster traffic to pass.
- Make sure the SMV (slow moving vehicle) emblem and all the lights and reflectors that are required by local authorities are in place, are clean, and can be seen by all over-taking and oncoming traffic. Always use hazard-warning flashers on tractor/towing vehicle when transporting unless prohibited by law.
- Do not transport during times of limited visibility such as fog, snow, or heavy rain. Take extra precautions at night and at dusk.
- Keep others away from the transport vehicle and seed treater.
- Do not allow riders on the seed treater or towing vehicle during transport.
- Stay away from overhead obstructions and power lines when operating and transporting. Electrocutation can occur without direct contact.
- Fully lower the seed treater before transporting, and only raise when next to storage facility.
- Attach to a proper towing vehicle with a pin and retainer. Always attach safety chain(s).
- Do not raise the intake end above drawbar, upending may occur.
- Empty seed treater of all grain or seed before transporting. Transporting a full seed treater will place excessive loads on the tube, frame, axle, hitch, and tow vehicle.
- Do not transport on slopes greater than 20°.
- Do not transport with an under-inflated tire(s).
- If the seed treater wheels are partially or fully buried in snow or grain, failure to clear area around the wheels before transporting may cause damage to the seed treater or result in serious injury.

5.2. Transport Procedure

The seed treater must be set into its transport position by securing the mover kit and proper connection to a tow vehicle.

1. Lower the conveyor intake using the hand winch until the stops on the conveyor contact the transport frame (see [Figure 7 on page 35](#) for the location of the winch).

Note

Leave some slack in the cable after lowering.

2. Lower the mixer tube fully using the controls, see [Figure 2](#).
3. Use the controls to raise the seed treater hitch.

Note

Confirm the conveyor lugs catch under the tow frame transport stops (see [Figure 3 on page 33](#)).

4. Insert pins in the tow frame.
5. Use the joystick to move the seed treater, aligning the hitch to the tow vehicle.
6. Connect to the tow vehicle, see [Section 12. – Specifications on page 108](#) for pin information.

Note

Hitch pin has a 1" diameter and a 3" minimum effective length.

7. Raise the mover kit fully and secure it using a safety cable/chain (not supplied), see [Figure 3](#).
8. Turn off engine.
9. Use the levers on each drive wheel to disengage the two hydraulic wheel drive motors.
10. Insert the pins in the lock out position.
11. Connect the safety chain securely to the towing vehicle, crossing underneath. Leave chains slack enough for angular movement.

 **WARNING** Do not tow with a worn or damaged safety chain.

12. If towing on a public roadway, connect transport lights (not supplied) and test each function before transporting.

Figure 2. Positioning Controls

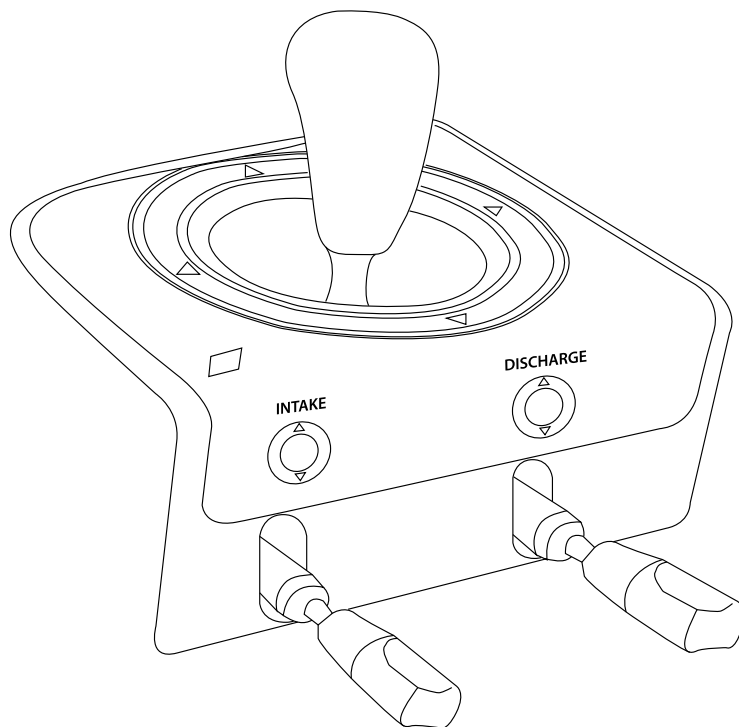

Figure 3. Conveyor Frame and Mover Kit Transport Locks

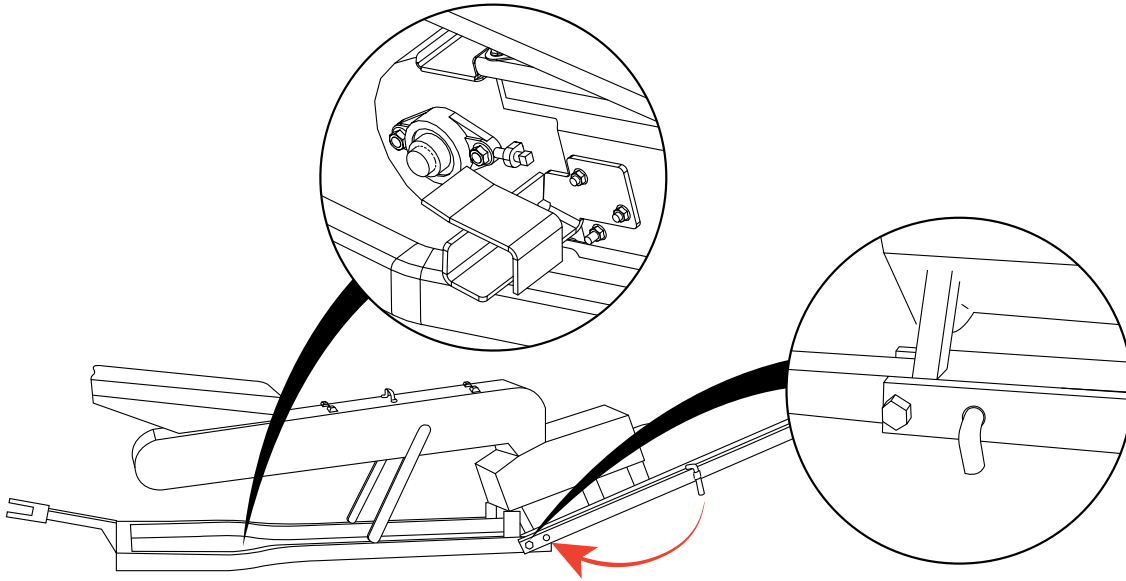

Figure 4. Correct Safety Cable Connection

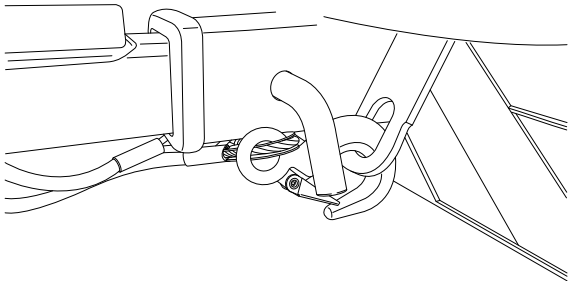
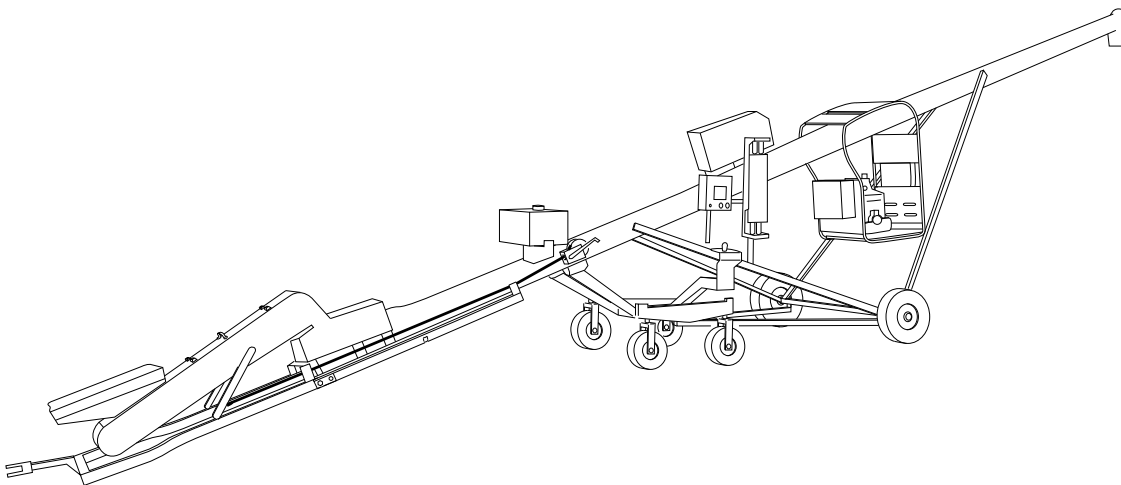

Figure 5. Transport Position



6. Placement



Before continuing, ensure you have completely read and understood this manual's Safety section, in addition to the safety information in the section(s) below.

6.1. Placement Safety

WARNING

- The seed treater is not insulated, keep away from overhead power lines. Electrocutation can occur without direct contact.
- Anchor intake end before using.
- Place the seed treater on reasonably level ground before operating. The seed treater could topple if ground is too uneven.
- Chock the seed treater wheels after placement.
- Check that wheels are free to move before raising or lowering the seed treater.
- Never attempt to increase height of the seed treater by positioning wheels on lumber, blocks, or by any other means.
- Do not permit anyone to stand beneath the seed treater when raising or lowering.
- Move the seed treater into position slowly. Do not unhitch and attempt to move by hand.
- Do not leave seed treater in raised position when not in use.
- Do not place in standing water.
- Ensure the supply cord is in good condition and that you are using a properly grounded outlet.

6.2. Position the Seed Treater

When properly positioned for treating, the transport frame will be on the ground and the conveyor intake will be under the seed discharge (hopper bin).

1. With the transport frame off the ground, remove and store the transport lock pins.
2. Remove the hitch and place in the transport rest.
3. Use the controls to position the seed treater partly under the bin, resting the intake end on the ground, refer to [Figure 6](#).
4. Use the joystick to move the seed treater fully under the bin and position the conveyor intake under the bin.
5. Use the intake control level to rest the transport frame on the ground.

Important

If you cannot adjust the equipment to ensure the mixer boot contacts the ground, place wheel chocks under the main drive wheels to prevent the equipment from shifting during operation.

6. Use the mixer discharge control to raise the discharge spout above the truck. Keep some clearance between the bottom of the discharge spout and the truck.
7. Adjust the conveyor intake next to the seed discharge (hopper bin) so that it is nearly contacting it. Use the manual winch to raise/lower the conveyor, see [Figure 7](#).

Note

This allows the conveyor to be flood filled and improves treating accuracy.

Figure 6. Positioning Controls

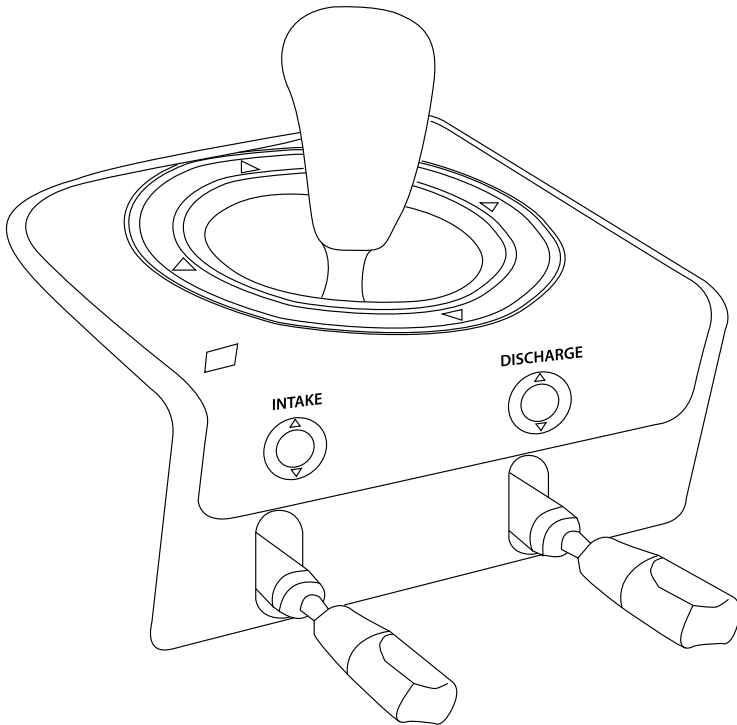
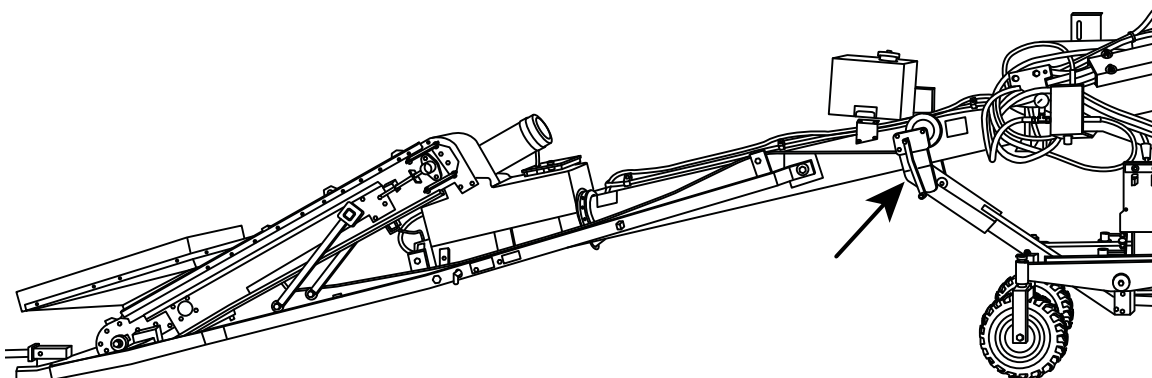

Figure 7. Manual Winch Location



7. Operation



Before continuing, ensure you have completely read and understood this manual's Safety section, in addition to the safety information in the section(s) below.

7.1. Operation Safety



- Keep away from rotating and moving parts, including the conveyor belt, auger flighting, drive components, shafts, and bearings.
- Do not enter the grain bin or truck while the seed treater is operating.
- Always operate with guards, covers, and shields in place.
- Ensure hoses connecting treatment containers to the equipment do not pose a tripping hazard.
- Have another trained person nearby who can shut down the equipment in case of accident.
- Keep the work area clear of bystanders.
- Keep the work area clean and free of debris.
- Ensure maintenance has been performed and is up to date.

7.2. Pre-Season Tasks

Complete the following tasks annually before starting each treating season.

- Review the Emergency Response Plan with all personnel who will be operating and assisting with operation of the seed treater, see [Section 4.1 – Emergency Response Plan on page 29](#).
- Check for and Install control system software updates, see [Section 11.2 – Updating System Software on page 105](#).
- Complete pre-season maintenance, see [Section 9.2 – Maintenance Schedule on page 75](#).

7.3. Conveyor Break-In

[Table 3](#) lists the recommended break-in activities for the conveyor assembly.

Table 3. Recommended Conveyor Break-in Activities

Time	Speed	Activity
30 min	70%	Run the conveyor unloaded, check for any problems.
10 min	100%	Run the conveyor at full speed with seed (if possible), but do not run pumps. During this time the mixer should also be run at the highest speed.

It is normal for small chunks of rubber to separate from the intake seals during break-in.

Ensure the belt is tracking in the center of the conveyor. Wing seals should contact the rubbers on both sides of the conveyor intake.

If any unusual noises or vibrations are encountered, determine the source, shut the conveyor off, lock out the power source, and adjust. If unsure of the problem, or the procedure to fix it, contact your local dealer.

7.4. Treating Seed

Overview

To treat seed, you need to perform a test weight procedure, create a job, calibrate the pumps, apply treatment and run the mixer, shut down the seed treater, and finally clean up the site. These options are covered in the sections that follow.

7.4.1 Engage and Disengage Pump Hoses

The pumps are equipped with two or three hoses. The number of hoses required while treating depends on the characteristics of the treatment and the desired application rates. The seed treater has a simple two position configuration for engaging and disengaging the pumps.

1. Release both locking knobs (4).
2. Swing the pump shoe retainers (5,6) down and out of the way.
3. Select the hoses (3) to be engaged and place the pump shoe in the [Figure 9](#).
4. Swing the inner pump shoe retainer (5) into place.
5. Place the engaged hoses flow valves (1) in the open position (see [Figure 10](#)).
6. Place the disengaged hoses pump shoe retainers in the disengaged position.
7. Swing the outer pump shoe retainer (6) into place and secure with the locking knobs.

Note

Tighten the knobs until the pump shoes are fixed firmly in place.

8. Place the disengaged hoses' flow valves in the closed position.

Figure 8. Pump Overview

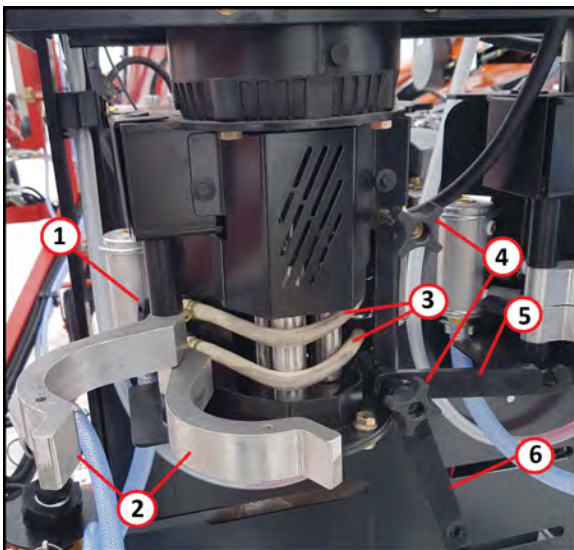

Item	Description
1	Flow Valve (1 per hose)
2	Pump Shoe (1 per hose)
3	Pump Hose*
4	Locking Knob
5	Inner Pump Shoe Retainer
6	Outer Pump Shoe Retainer

Figure 9. Pump Shoe Engaged and Disengaged Positions

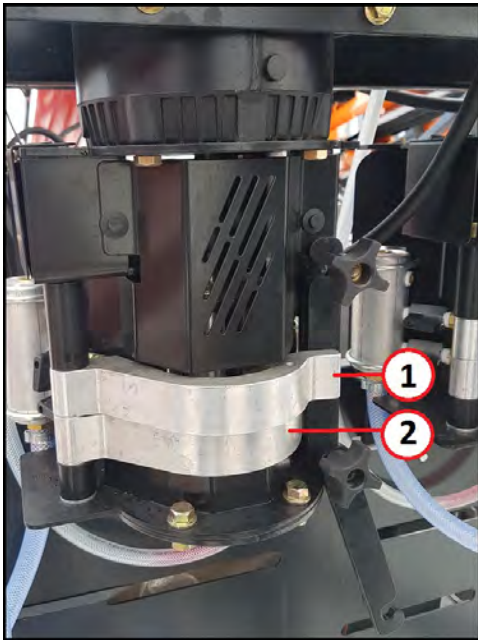

Item	Description
1	Pump Shoe in Disengaged Position
2	Pump Shoe in Engaged Position

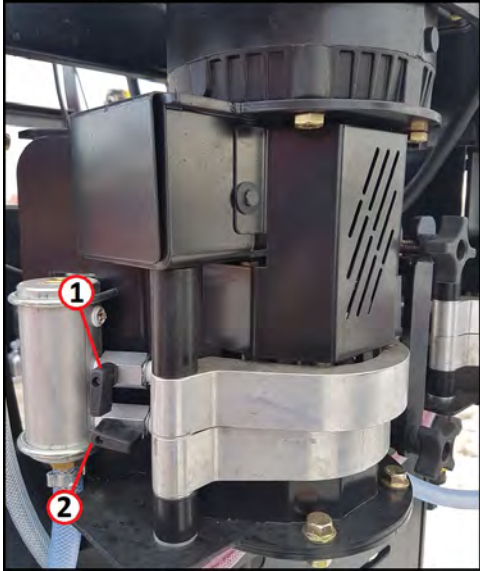
Figure 10. Flow Valve Open and Closed Positions

Item	Description
1	Flow valve in Closed Position
2	Flow valve in Open Position

7.4.2 Create a Job

To create a new job, first give it a name, then enter information about the seed, followed by selecting or entering treatment information. A maximum of 20 jobs can be configured and stored for use.

The gas engine does not have to run to create a job.

1. Go to the Job screen and follow the prompts to start a New Job.

Note

New jobs can be created either by starting from a job with all parameters blank, or by copying an existing job and continuing to use it with a different name.

2. Enter a Job Name (description).

Note

Use the treatment type and seed product as the job name, such as “Wheat— Raxil Pro.”

3. Enter the seed information including seed type, density (grams per 0.5 L), and desired treating speed. For seed density measurement procedure, refer to [Section 11.1 – Test Weight Procedure on page 104](#).
4. Enter treatment information including treatment name, application rate (label rate), and dilution rate. There may be pre-programmed treatments listed or custom treatments can be entered.

Note

Custom treatments require a treatment name, application rate, and dilution amount to be entered. Dilutions are considered based on the treatment product. Adding equal parts of water to a treatment is considered 100% dilution. Custom treatments can be saved and used in subsequent jobs.

The job is now created. Next, calibrate the pumps before operating the treater and treating seed.

7.4.3 Calibrate the Pumps

Calibrating the pumps enables the seed treater to provide the correct amount of treatment for the anticipated seed flow. Calibration requires the use of the calibration cylinders, treatment products, and the calibration control screens accessed via the touchscreen display.

The pumps need to be calibrated when:

- a job is created.
- the outdoor temperature changes. For example, colder weather will increase the viscosity of some treatments and make the pump less efficient.
- pump tubing wear may impact pump output.
- the treating speed in a job has been changed due to a seed flow correction.

The calibration procedure is divided into the topics that follow.

Prepare for Calibration

If you will be using both pumps, using pump one for the more viscous (thickest) product will speed up the calibration process.

1. Connect to the seed treatment product container.

Important

Air leaks in the connection between treatment product and intake lines affect the accuracy of the calibration and treatment processes. Contact the manufacturer of the treatment product container to determine connection requirements. If the container has a one way valve, it may be necessary to use an alternate container.

NOTICE

Equipment damage may occur if the calibration cylinder cannot be properly emptied during the calibration procedure.

2. Set the valve to the calibrate position for the pump(s) being calibrated.

Collect 1000mL

The foundation of the calibration procedure is the collection of product in the calibration cylinder. Each time you perform a test, the seed treater attempts to collect 1000 ml of product. Successfully collecting 1000 ml allows you to run your job with the parameters you set during its creation. Collecting less or more than 1000 ml results in parameters that differ from your target.

Set the Treating Speed

Understanding the following variables is crucial to effective calibration:

Target Treating Speed: The target treating speed is set as a constant in the job parameters. By default, the target treating speed is 100%. Collecting 1000 ml during a test results in a successful calibration that matches the target treating speed. When the calibration is successful, the system displays a Calibration Successful Outcome Screen. On the Calibration Successful Outcome Screen you can view the treating speed used for the job, and may proceed to calibrate a second pump, or proceed to save the job parameters and begin treatment.

Resulting Treating Speed: The resulting treating speed is the treating speed achieved from a calibration test. It may be more or less than the target treating speed you set when creating the job. The software system allows you to use the resulting treating speed in place of the target treating speed.

Note

If the resulting treating speed is outside the physical capabilities of the equipment, an invalid result message appears on the results screen.

Re-Calibrate the Pumps

After the initial calibration, each time a job is run, it is recommended that you re-calibrate the pumps. The system saves the treating speed and pump calibration parameters after a calibration is performed, and uses those values the next time the job is run. Re-calibrating before a job is run again ensures you are treating accurately.

Correct Calibration Errors

It is possible that the treating speeds achieved in the calibration tests are not exact matches. This results in an error which is displayed on-screen as a percentage. The percentage indicates the degree of inaccuracy in product application that will occur if you run the job without correcting the error. You may choose to accept the error and proceed with the job. You can continue with a calibration to eliminate the error. The software system informs you when you have accepted an error.

Note

If a “9” is displayed in front of the three digit calibration number (rpm), this means that the pumps are using an estimated value for calibration and should be re-calibrated. The “9” will disappear once the system is re-calibrated.

Complete Second Pump Calibration and Prepare for Treating Seed

1. Repeat the calibration procedure for multiple pumps (if applicable).
2. Switch the calibration valve from the “calibrate” position to the “treating” position.

7.4.4 Operate the Treater & Treat Seed

When operating the seed treater for the first time, the chemical hoses may be filled with antifreeze and will need to be flushed out. Refer to the appropriate procedures in the Maintenance section.

1. Start the engine and bring to operating temperature.

Note

Consult the gas engine operating manual for proper procedure for starting the engine.

2. Flood the intake hopper completely with seed.
3. Select the job to use and verify that the seed and treatment parameters are correct for the application.
4. Connect the seed treatment containers to the pumps.
5. Prime the pumps. Make sure treatment is at the mixer boot/nozzles.
6. Prime the conveyor with seed. Make sure that seed is at the mixer boot/nozzles.
7. Continue to the operation screen.
8. Start the mixer empty and set it at 350 mixer RPM, forward direction.
9. Enter a specific amount of seed to be treated if desired. The treater will run until the amount is reached or the operator stops the machine.
10. Start treating seed— conveyor, mixer, and pumps will start running.
11. Adjust mixer rpm to ensure that it is adequate for the application.
12. Run until the desired amount of treated seed is obtained. Stop treater. Do not stop the mixer until the it is empty.
13. Adjust the seed flow calibration, if required.

7.4.5 Update the Calibration

After a batch of seed is treated or continuous operation has ended, a seed flow correction screen will be displayed showing the estimated weight of seed that was treated and will prompt the operator for actual weight of seed treated. Entering the actual weight will improve treating precision for the next job.

1. Weigh the actual amount of seed that was treated.

Note

If you don't know or are unable to determine the exact amount of seed that was treated, you can use the amount estimated on the screen.

2. Enter the actual weight. The electronics will recalculate the seed delivery and required treatment flows and correct the pump rpm automatically.
3. The system will then ask you to re-calibrate to verify that its adjustments are correct. Re-calibrate as required, see [Section 7.4.3 – Calibrate the Pumps on page 40](#).
4. The corrections will be saved for use the next time the job is utilized.

7.5. Emergency Stop

Although it is recommended that the seed treater be emptied before stopping, in an emergency situation press the emergency stop button. The emergency stop will stop the conveyor, seed treatment metering pumps, and spray nozzles. The mixer has a manual hydraulic shut off valve located directly next to the touch screen controls..

Do not use the emergency stop as a lockout for equipment service or maintenance.

Do not use the emergency stop to shut the equipment down in place of the control panel stop button. Records may be lost.

For the location of the emergency stop button, refer to [Section 3. – Features on page 27](#).

7.6. Restarting a Full Seed Treater

The seed treater may be filled with material if it is shut down inadvertently or for an emergency. To restart:

1. Shut off the conveyor.
2. Run the mixer tube until empty. If that isn't possible, lift the mixer boot, place a catch pan underneath, open the boot clean-out, and then run mixer flighting backwards.
3. Close any clean-out doors, return the seed treater back to its operating position, re-start the system and resume treating.

7.7. General Clean-Out Procedure

Complete a general clean-out after each treatment is completed or before switching treatment types. A more thorough, advanced clean-out should be completed at the end of each day, or more often if desired, see Maintenance section for advanced procedure.

1. Run the mixer until empty.
2. Lift the mixer boot off ground and place a catch pan under the boot clean-out door.

3. Raise the mixer (for better flow back). Open the mixer boot door and run the mixer backwards until it is empty.
4. Go to the flush-out screen.
5. Run metering pumps backwards until empty.
6. Connect the pump intake lines to a rinse water source and run the pumps backwards and forwards until lines are clear.

Note

Male couplers are included to allow for connection.

7. Open the boot cover. Use compressed air or water to clean out the mixer boot.
8. Open the conveyor covers to remove remaining untreated seed.
9. Clean the filter strainers, see [Section 9.10 – Clean the Filter Strainers on page 80](#).
10. Dispose of collected waste in accordance to local standards and/or as defined by seed treatment product labels.

7.8. Chemical Spill Cleanup

When operating the seed treater, keep spill clean-up gear at the work area. At minimum, have an aluminum shovel, broom, bag of absorbent material, and paper towel available.

It is recommended to also carry heavy duty garbage bags, water, and other clean-up materials as recommended by the seed treatment manufacturer. Ammonia or bleach cleaners can be helpful when cleaning up treatment stains.

Seed Treatment Spill - Small

1. Use paper towel and wipe up or use a shovel and broom as applicable.
2. Dispose of waste as per seed treatment manufacturer's label instructions or at an approved chemical waste disposal site.

Seed Treatment Spill - Large

1. Use a combination of absorbent material and paper towel to soak up the spill or use a shovel and broom as applicable.
2. Dispose of waste as per seed treatment manufacturer's label instructions or at an approved chemical waste disposal site.

Treated Seed Spill

Use shovel and broom to retrieve and dispose of treated seed as per the treatment manufacturer's label recommendations.

7.9. Storage

After the season's use, the seed treater should be thoroughly inspected and prepared for storage. Repair or replace any worn or damaged components and perform maintenance as described in the Maintenance Section to prevent any unnecessary downtime at the start of the next season.

To ensure a long, trouble-free life, this procedure should be followed when preparing the unit for storage.

1. Remove all residual material from the mixer and mixer boot, conveyor and conveyor intake.
2. Wash the seed treater thoroughly using a water hose or pressure washer to remove all dirt, mud, debris, or residue.
3. Inspect all moving or rotating parts to see if anything has become entangled in them. Remove any entangled material.
4. Winterize the equipment according to [Section 9.11 – Fill the System with Antifreeze on page 81](#).
5. Touch up all paint nicks and scratches to prevent rusting.
6. Check tire pressure and inflate. For inflation pressure, refer to [Section 12. – Specifications on page 108](#).
7. Inspect the seed treater for cracks, tightness of fittings and fasteners, hydraulic hose cracks (if applicable). Have required repairs performed to replace worn or damaged components.
8. Store in an area that is dry, level, free of debris, and away from human activity. Store inside if possible.
9. Cover the conveyor intake and motor with a waterproof tarpaulin if stored outside to protect from weather.
10. Chock wheels.
11. Support intake on blocks to eliminate prolonged contact with the ground.
12. Coat exposed hydraulic cylinder shaft(s) with a light film of grease to protect from the environment.
13. Open the pump shoes to release pressure on the tubing.
14. Place the seed treater in its transport position.
15. Ensure cover is closed over control box.
16. Store gas engine as per manufacturer's recommendations.

8. Software Screens

This section describes all of the software screens and how to navigate through them.

8.1. Electronic Controls

Treatment application is controlled through the system software.

The main menu, which shows the graphical buttons for the four main control sub menus, can be seen in [Figure 11](#).

Figure 11. STORM Touch Screen Main Menu



8.2. View and Configure Current Date and Time

Note

Date and time persist in the control unit memory after power is removed from the system, and generally does not need to be adjusted, with the exception of correcting for time zones and local daylight savings.

From the main menu, tap:

Setup — Set Date And Time

- Set the date and time using the touch screen.
- Tap **Save Changes** to save the new settings and return to the Setup menu.
- Tap **Back** to abandon any changes and return to the Setup menu.

Figure 12. Set Date and Time



8.3. View Software Version

From the main menu, tap:

Setup — Software Version

- Tap **Back** to return to the Setup menu.

Figure 13. View Software Version

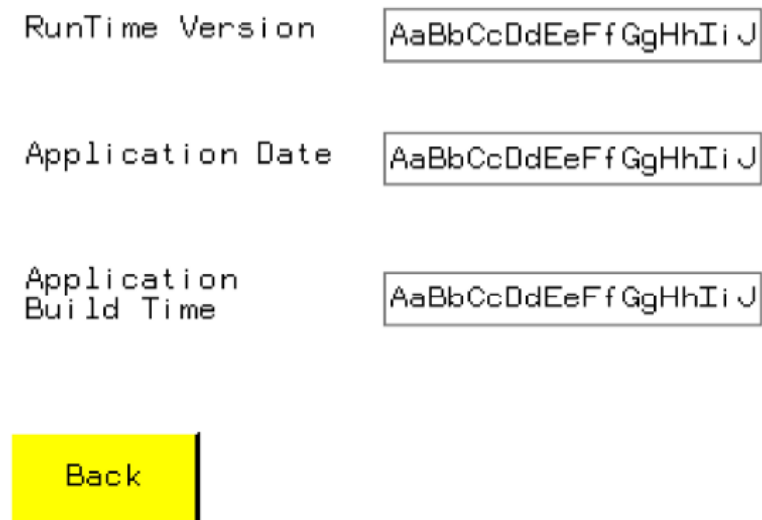

Table 4. View Software Version

Item	Description
Runtime Version	The release number of the operating system that runs the STORM application software.
Application Date	The release date of the currently loaded STORM application software.
Application Build Time	The time of day that the current application software was compiled for release.

8.4. View and Configure Pump Setup

Pump setup informs the system about what pumps and pump tubing sizes are in use, which allows the system to accurately warn the operator when a job is not compatible with the current pump/tubing setup.

A default configuration is pre-programmed with factory settings that are typical for general use. Always update pump setup to reflect actual pump configuration for the job every time the STORM is powered up to perform seed treating.

From the main menu, tap:

Setup — Pump 1 Setup or Pump 2 Setup

- Tap the tubing type (I/P) to reflect the physical setup of the system.
- Tap **Back** to abandon any changes and return to the Setup menu.
- Tap **Save and Continue** to save changes and return to the Setup menu.
- Tap **Advanced** to view or make changes to advanced pump setup parameters under the guidance of AGI service staff.

Figure 14. Pump Setup (Pump 1 and Pump 2)

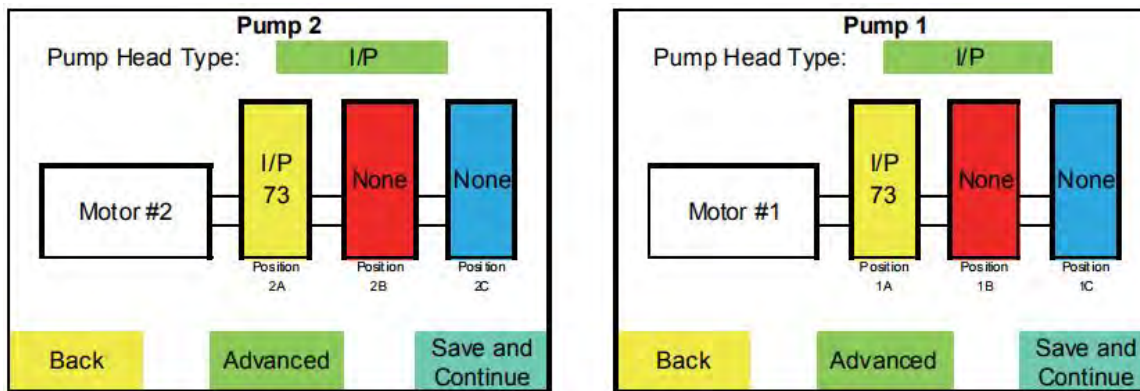

Table 5. Pump Setup Screen Fields

Item	Description
Motor	Indicates the motor/pump position: #1 or #2 (pump 1 or pump 2)
Position	Indicates the ganged pump position: 1A, 1B, 1C (for pump 1) or 2A, 2B, 2C (for pump 2).

Table 5 Pump Setup Screen Fields (continued)

Item	Description
	<p>“A” indicates the inner pump head, “B” the middle pump head, and “C” the outer pump head. The “B” and “C” positions are configured only when additional pump heads are equipped.</p> <p>The pump tubing type for each pump position is displayed as one of the following: I/P 26, I/P 73, or NONE. Each tubing type must match the pump it is used on. NONE indicates that the pump head is not used (and may not actually be installed).</p>

8.5. View and Configure Advanced Pump Setup

Note

Do not adjust any advanced pump parameters unless directed to do so by an AGI service professional.

From the main menu, tap:

Setup — Pump 1 Setup or Pump 2 Setup — Advanced

- Tap and change the low- and high-speed limits according to the direction of an AGI service professional.
- Tap **Back** to abandon any changes and return to the Setup menu.
- Tap **Save and Continue** to save changes and return to the Setup menu.

Figure 15. Advanced Pump Setup

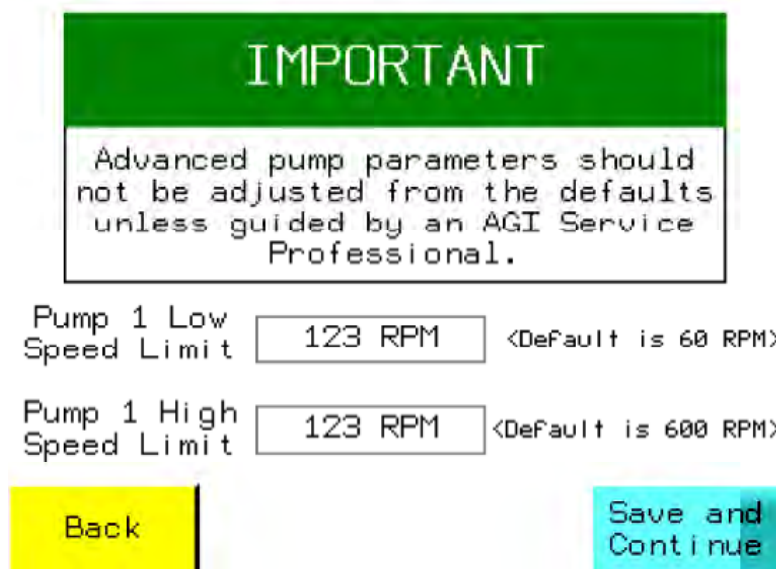

8.6. View and Configure Conveyor Options

Important

Do not adjust any conveyor parameters unless directed to do so by an AGI service professional.

From the main menu, tap:

Setup — Conveyor Options

- Tap and change the Conveyor Drive Ratio and Conveyor Correction Factor according to the direction of an AGI service professional.
- Tap **“Back”** to abandon any changes and return to the Setup menu.
- Tap **“Save and Continue”** to save changes and return to the Setup menu.

Note

Default Conveyor Drive Ratio is 10:1. The Default Conveyor Correction factor is 1000 (100%) with limits of 800 to 1200 (+ or - 20%).

Figure 16. Conveyor Options

The screenshot shows a screen titled "CONVEYOR OPTIONS". At the top, there is a green banner with the word "IMPORTANT" in white. Below this, a bold warning reads: "Consult an AGI service professional before making adjustments." Two lines of text follow: "Changing the Drive Ratio Value is not recommended." and "Changing the Conveyor Correction Factor can seriously affect all metering functions of the STORM." Below the text are two input fields. The first is labeled "Conveyor Drive Ratio" and contains the value "12.12 : 1" with a note "<Default is 10.00>". The second is labeled "Conveyor Correction Factor" and contains the value "1234" with a note "<Default is 1000>". At the bottom left is a yellow "Back" button, and at the bottom right is a cyan "Save and Continue" button.

8.7. Viewing Configured Jobs

From the main menu, tap **Jobs**.

Jobs are displayed in several pages. Use **“More”** and **“Back”** to page through configured jobs.

Newest created jobs will appear highest in the list.

Selecting a job from the list will take you to Job Options Screen.

Figure 17. Jobs Screen



8.8. Deleting a Job

From the main screen, tap **Jobs** — <select job> — **Delete** — **Yes**

Figure 18. Confirm Job Delete

Are you sure you want to delete all parameters and history attached to Job :



8.9. Viewing Job Parameters

From the main screen, tap **Jobs** — <select job> — **Start Treating:**

The first job parameter screens are the pump configuration screens, which appear only if the current pump configurations are different than those for the selected job.

Tap **Continue** to view the Job parameters Screen 1, and then tap **Continue** again to view Job parameters Screen 2.

Figure 19. Job Parameters

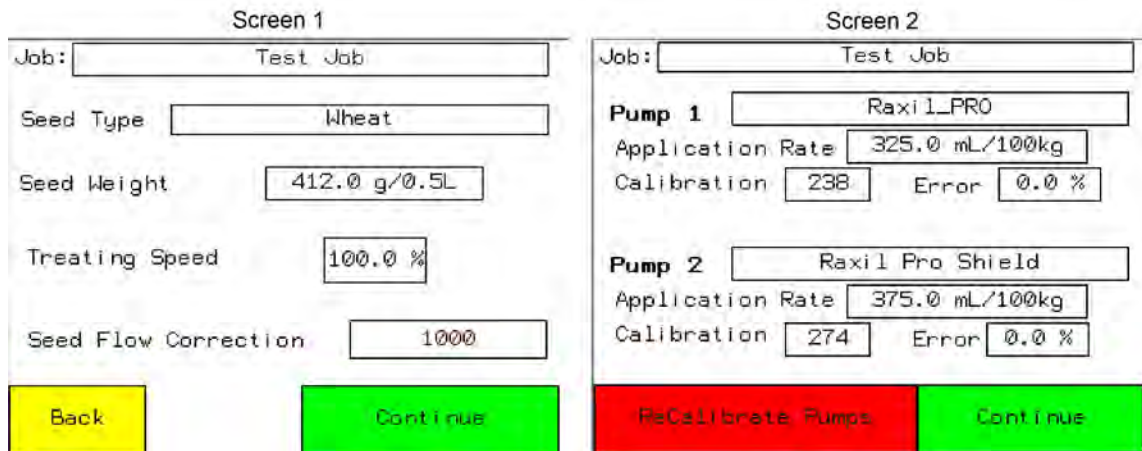

Table 6. Viewing Job Parameters

Field	Description	Value
Job	The name of the job, used to uniquely identify the job from all other configured jobs.	1-30 letters and characters
Seed Type	The type of seed configured for the job.	wheat, barley, oats, peas, lentils, etc.
Seed Weight	The configured seed weight for the job.	160-500g/0.5 L
Treating Speed	The configured conveyor speed for the job.	50-100% (can be as high as 102% based on pump calibration).
Seed Flow Correction	Used only for all seeds. Represents the cumulative seed flow correction for the seed used in the job.	—
Pump	Indicates the pump for the adjacent information fields, and displays the name of the treatment assigned to the pump.	Pump 1 or Pump 2
Application Rate	Displays the application rate configured for the job.	10 to 1200 ml/100 kg
Calibration	Displays the current calibration number for the job.	60-600
Error	Only used in two pump calibration to indicate a difference in the treating speed obtained by one of the pumps. Illustrates the results over (+) or under (-) application of treatment.	+/- 0 - 20% (The system indicates that a job has been run without recalibrating by adding a 9 in front of the value)

8.10. Viewing Treating History (All Jobs)

From the main screen, tap **Jobs — History**:

The treating history maintains the details of the 40 most recent jobs. The treating history can be reviewed directly on the HMI by tapping the arrows and scroll bar to the right of the history details (see [Figure 20 on page 53](#)).

Tapping **Save to USB** allows you to save the history to a micro-USB flash drive installed in the USB port on the front panel. This button turns green then back to grey when the save is complete.

Tapping the **?** button displays the format in which the Treating History is saved.

Note

The STORM system saves the history file into the root directory of the USB flash drive unless the USB is storing software. In the event that the USB flash drive is storing software, the history file is saved as follows:

The STORM system saves the history file to the USB flash drive path “public/projects/magelis/data/ alarm/eventgroup1”, with the file name:

AHyyymmdd#####.CSV

where:

AH is the prefix for all history files

yy is the year

mm is the month

dd is the day

is a six-digit number that identifies multiple files saved on the same day.

Important

The treating history file is saved in CSV (comma separated values) format, which can be opened in common spreadsheet software (e.g Microsoft Excel).

If the system estimates that there is five or fewer treatment entries remaining, the following warning message is displayed:

- “Treating History is almost full. Please save records to a USB flash drive to prevent loss of treating history.”

When treating history is completely full, the following warning message is displayed:

- “Treating History is FULL. Oldest treating records will be written over. Please save records to a USB flash drive to prevent loss of treating history.”

Figure 20. Treating History

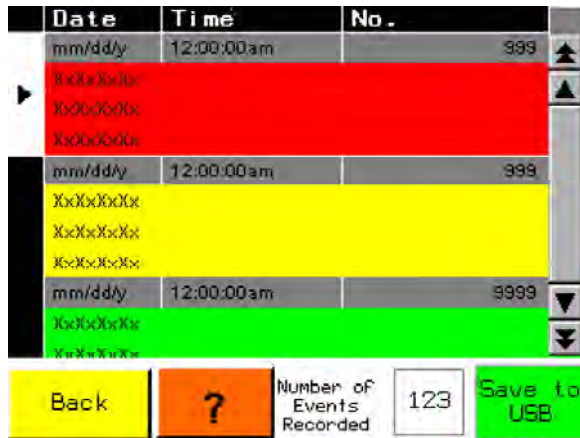

Treating History Message Format

Date (yy/mm/dd), Time (24 hour), Job Name, Seed Type, Seed Calibration Weight, Seed Flow Correction, Seed Treated (lbs), Pump 1 Product Name, Pump 1 Application Rate, Pump 1 Calibration Number, Pump 1 Calibration Error, Pump 1 Litres Used, Pump 2 Product Name, Pump 2 Application Rate, Pump 2 Calibration Number, Pump 2 Calibration Error, Pump 2 Litres Used

8.11. Viewing Treating History (Specific Job)

From the main screen, tap **Jobs** <select job> — **Job History**:

The job treating history maintains the details of the last three times that the selected job has been run to completion. Treating history also displays:

- the total number of times the job has been used
- the total amount of seed used by the job
- the total amount of treatment used by the job

The newest entry is at the top of the list, and the oldest entry at the bottom is replaced when a new batch is complete.

Figure 21. Job Treating History

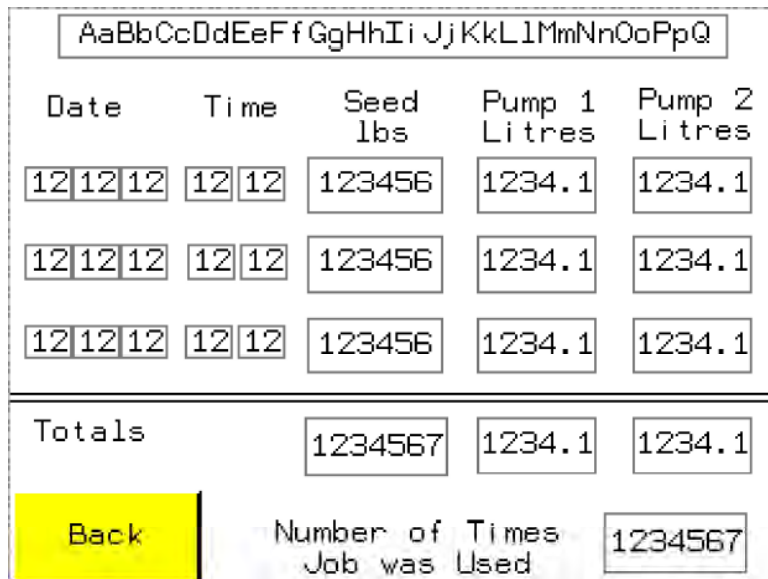
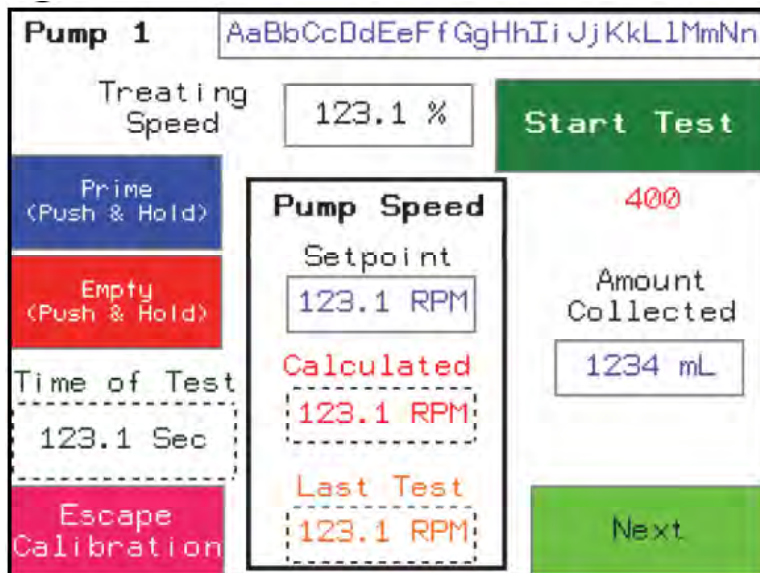

Table 7. Viewing Job Treating History Parameters

Field	Description
Job	The name of the job.
Date / Time	The date and time that the job was run.
Seed lbs	The actual (if entered after a batch completes) or estimated weight of seed treated when the job was complete.
Pump 1 Litres	The amount of treatment fluid used in this instance of treating for Pump 1.
Pump 2 Litres	The amount of treatment fluid used in this instance of treating for Pump 2.
Totals	Provides totals for Seed lbs, Pump 1 Litres, Pump 2 Litres for all uses of the job (not just the totals for the three most recent uses).
Number of times Job was used	Indicates the number of times the job has run.

8.12. Calibrate a One Pump Job

Figure 22. Calibration Test Screen



1. Connect the pumps to the treatment containers
2. Set the valve associated with the pump to the calibrate position.
3. From the Job Parameters Screen (see [Figure 19 on page 51](#)), tap **Calibrate Pumps** to open the calibration test screen (see [Figure 22 on page 54](#)).
4. Tap and hold **Prime** until 500 ml of product has been collected in the calibration cylinder.

Note

Ensure there are no air bubbles in the line.

5. Tap and hold **Empty** until the liquid is at the zero mark.
6. Tap **Start Test** to start the countdown.
7. After the countdown is complete, tap the flashing **Amount Collected** box and enter the number of ml collected in the cylinder during the test.
8. Tap **Next**.
9. Review the screen generated by the system and decide your next action. The system will generate one of the following screens:

Figure 23. Calibration Successful Outcome Screen

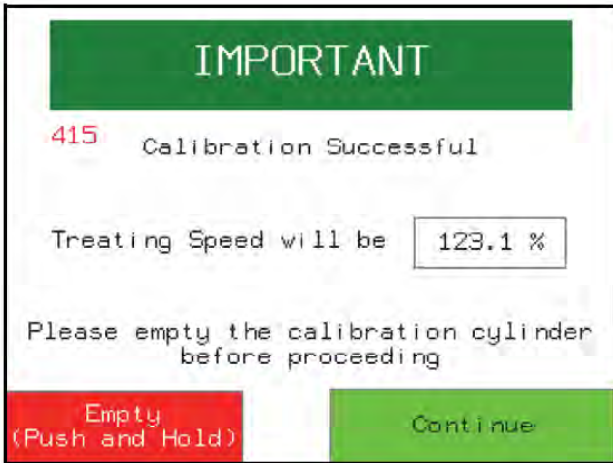

This screen appears when you collected 1000 ml and achieved your target treating speed.

- Tap **Empty** to empty the calibration cylinder.
- Tap **Continue** to return to the Jobs Screen.

Figure 24. Calibration Results Screen

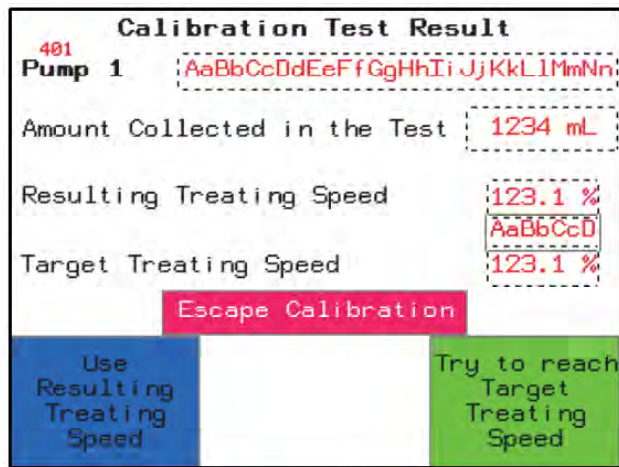

This screen appears if you did not achieve your target treating speed.

- Tap **Try to reach Target Treating Speed** to perform another test and return to step 3.
- Tap **Use Resulting Treating Speed** to accept the treating speed achieved during the test and proceed to step 9.
- Tap **Escape Calibration** to quit the calibration procedure.

10. Tap and hold Empty (see [Figure 25 on page 56](#)).

Figure 25. Calibration Outcome Screen

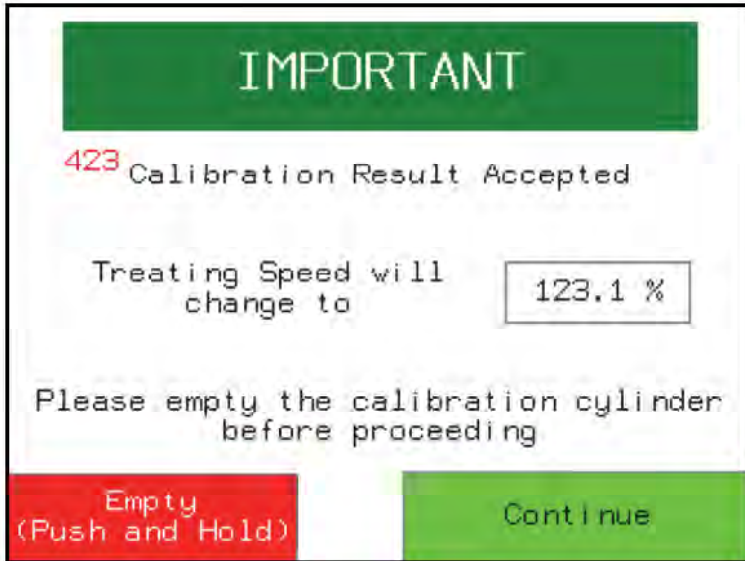

11. Tap **Continue** to end the calibration procedure and return to the Job Screen.

8.13. Calibrate a Two Pump Job

Set both valves to the calibrate position.

Calibrate Pump One

Figure 26. Calibration Test Screen

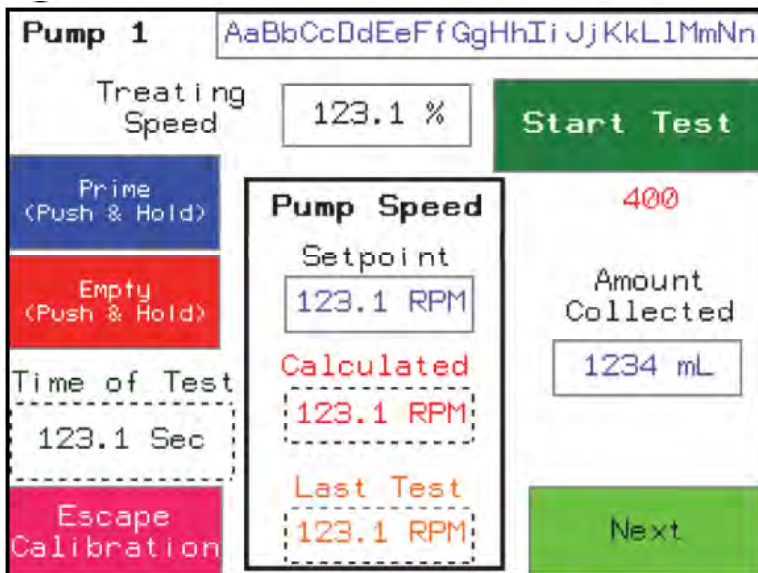

1. Connect the pumps to the treatment containers.
2. Set the valves associated with each pump to the calibrate position.
3. From the Job Screen, tap **Calibrate Pumps** to open the calibration test screen (see [Figure 26 on page 56](#)).

4. Tap and hold **Prime** until 500 ml of product has been collected in the calibration cylinder.

Note

Ensure there are no air bubbles in the line.

5. Tap and hold **Empty** until the liquid is at the zero mark.

6. Tap **Start Test** to start the countdown.

7. After the countdown is complete, tap the flashing **Amount Collected** box and enter the number of ml collected in the cylinder during the test.

8. Tap **Next**.

9. Review the screen generated by the system and decide your next action. The system will generate one of the following screens:

Figure 27. Calibration Successful Outcome Screen

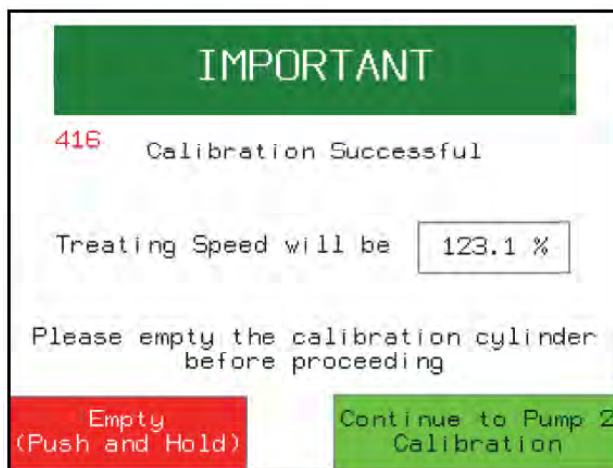

This screen appears when you collected 1000 ml and achieved your target treating speed.

- Tap **Empty** to empty the calibration cylinder.
- Tap **Continue to Pump 2 Calibration** to proceed to [Calibrate Pump Two on page 58](#).

Figure 28. Calibration Results Screen

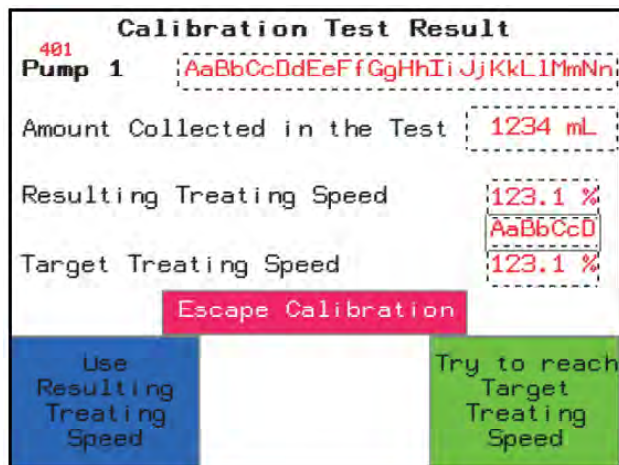

This screen appears if you did not achieve your target treating speed.

- Tap **Try to reach Target Treating Speed** to perform another test and returns to step 3.
- Tap **Use Resulting Treating Speed** to accept the treating speed achieved during the test and proceed to step 9.
- Tap **Escape Calibration** to quit the calibration procedure.

10. Tap and hold **Empty** (see [Figure 27 on page 57](#))

Figure 29. Calibration Outcome Screen

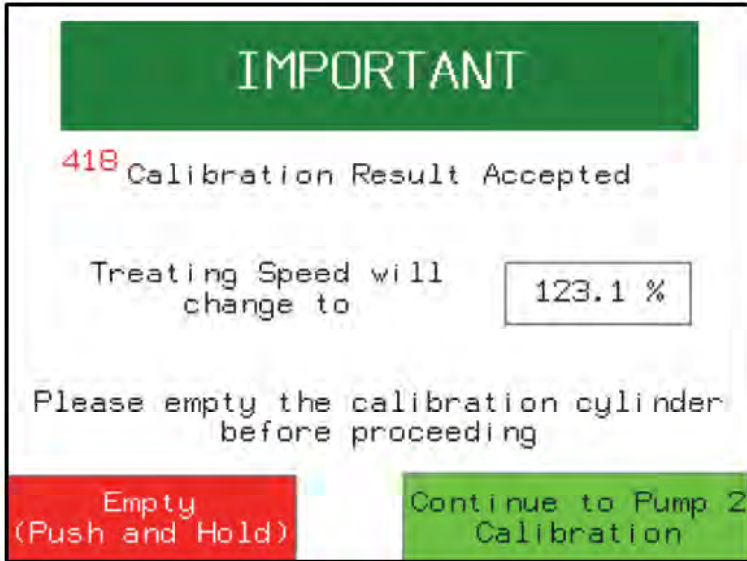

11. Tap **Continue to Pump 2 Calibration** to proceed to [Calibrate Pump Two](#) on page 58.

Calibrate Pump Two

Figure 30. Calibration Test Screen

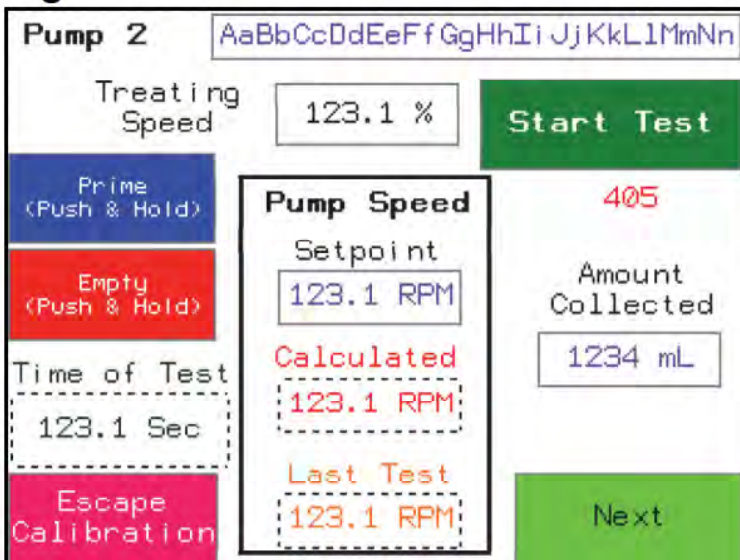

1. Tap and hold **Prime** until 500 ml of product has been collected in the calibration cylinder.

Note

Ensure there are no air bubbles in the line.

2. Tap and hold **Empty** until the liquid is at the zero mark.
3. Tap **Start Test** to start the countdown.
4. After the countdown is complete, tap the flashing **Amount Collected** box and enter the number of ml collected in the cylinder during the test.

5. Tap **Next**.
6. Review the screen generated by the system and decide your next action. The system will generate one of the following screens:

Figure 31. Calibration Successful

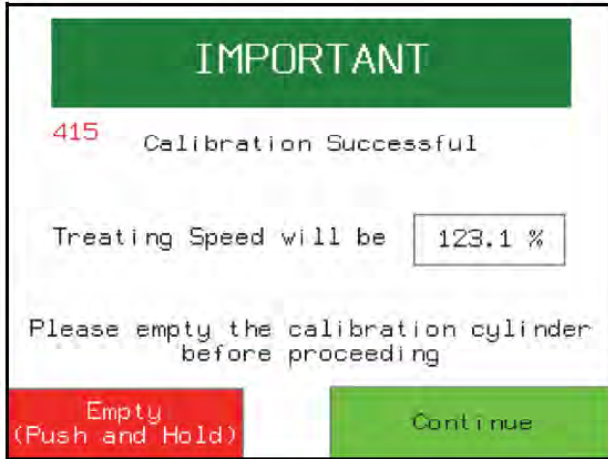

This screen appears when you collected 1000 ml and achieved your target treating speed.

- Tap **Empty** to empty the calibration cylinder.
- Tap **Continue** to return to the Jobs Screen

Figure 32. Calibration Results Screen

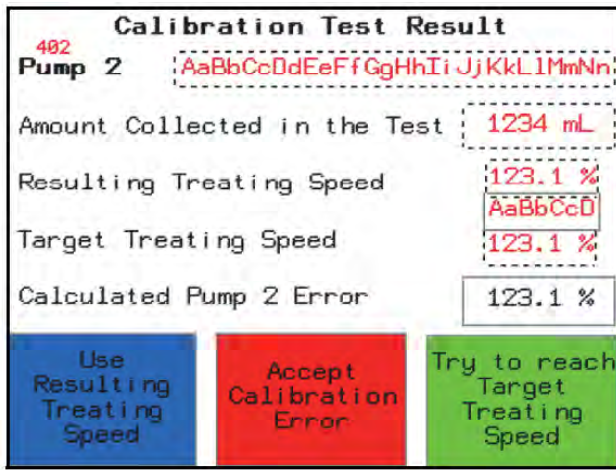

This screen appears if you did not achieve your target treating speed.

- Tap **Try to reach Target Treating Speed** to perform another test and return to step 1.
- Tap **Use Resulting Treating Speed** to accept the treating speed achieved during the test and proceed to [Recalibrate Pump One on page 60](#).
- Tap **Accept Calibration Error** to continue to step 7.

7. Tap and hold **Empty** (see [Figure 31 on page 59](#)).
8. Tap **Continue** to accept the error in the treatment application of pump 2 and return to the Job Screen.

Important

The maximum allowable error is 20%.

Figure 33. Calibration Outcome Screen

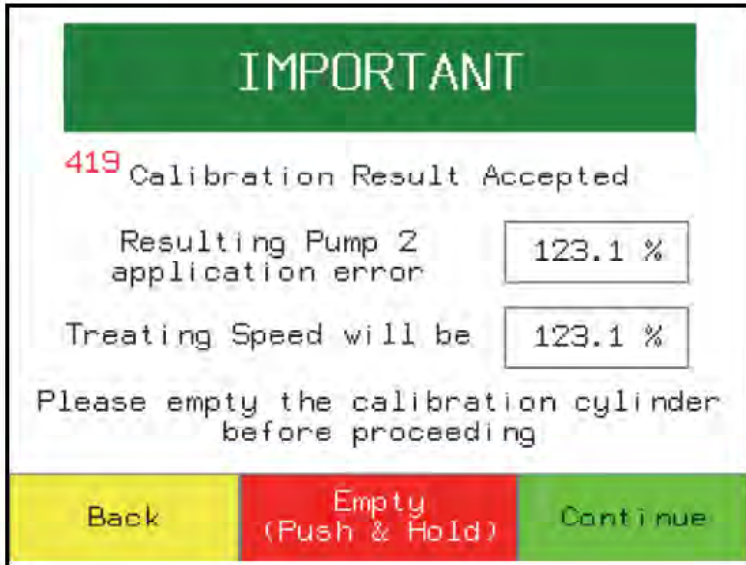

Recalibrate Pump One

1. Tap and hold **Empty** (see [Figure 34 on page 60](#)).
2. Tap **Recalibrate Pump 1**.

Figure 34. Calibration Outcome Screen

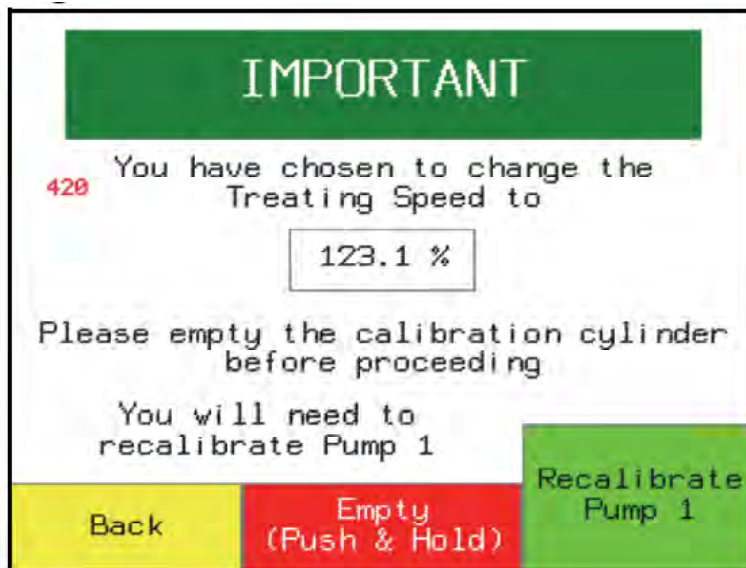

3. Tap and hold **Prime** until 500 ml of product has been collected in the calibration cylinder (see [Figure 35 on page 61](#))
4. Tap and hold **Empty** until the liquid is at the zero mark.
5. Tap **Start Test** to start the countdown.
6. After the countdown is complete, tap the flashing **Amount Collected** box and enter the number of ml collected in the cylinder during the test.

7. Tap **Next**.

Figure 35. Calibration Test Screen

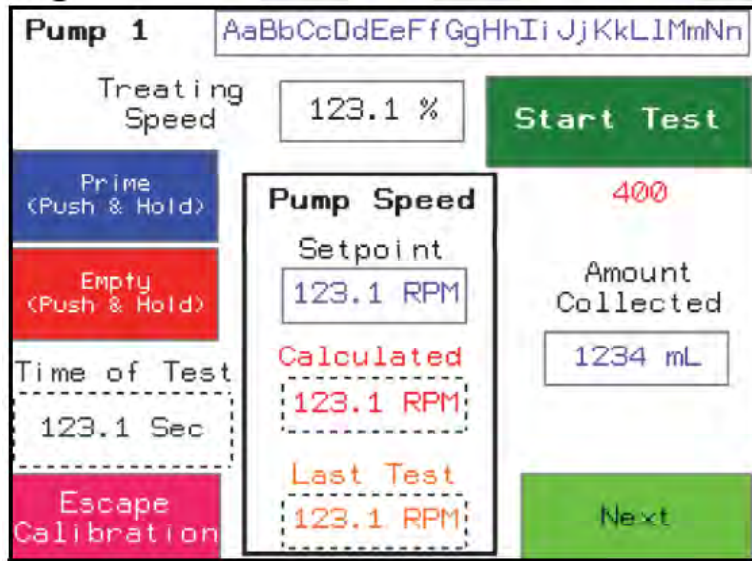

8. Review the screen generated by the system and decide your next action. The system will generate one of the following screens:

Figure 36. Calibration Successful

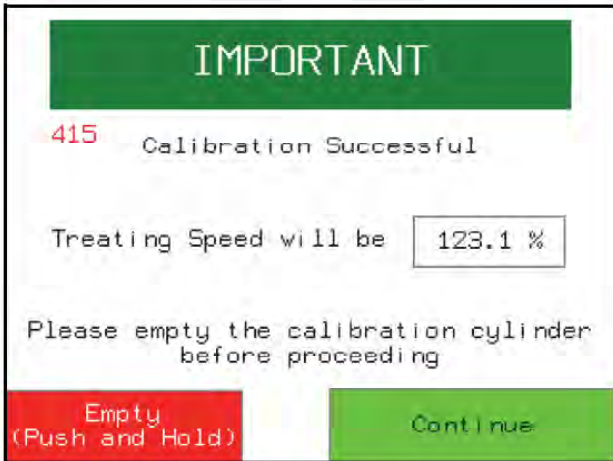

This screen appears when you collected 1000 ml and achieved your target treating speed.

- Tap **Empty** to empty the calibration cylinder.
- Tap **Continue** to return to the Jobs Screen

Figure 37. Calibration Results Screen

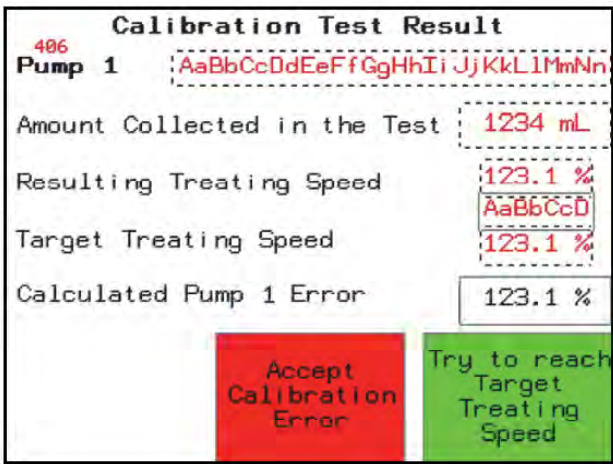

This screen appears if you did not achieve your target treating speed.

- Tap **Try to reach Target Treating Speed** to perform another test and return to step 3.
- Tap **Accept Calibration Error** to proceed to step 9.

9. Tap and hold **Empty** (see [Figure 38 on page 63](#)).

10. Tap **Accept Calibration Error** to accept the error in the treatment application of pump 1 and return to the Job Screen.

Figure 38. Calibration Outcome Screen

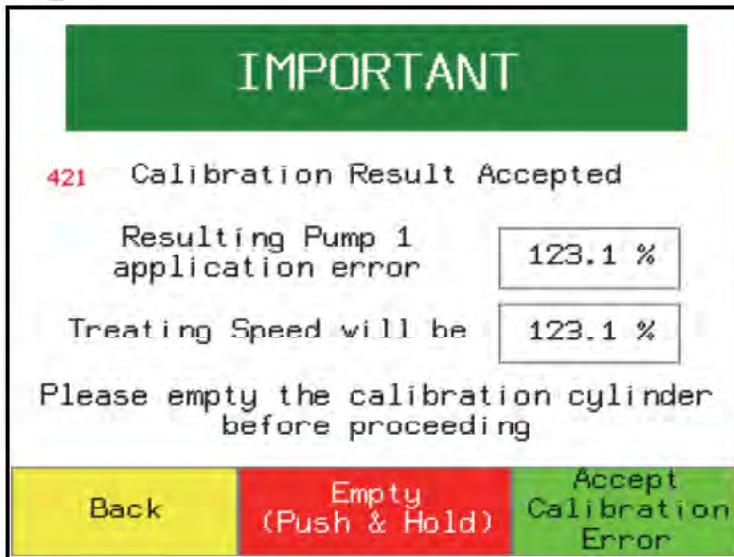

8.14. Calibration Results

Reading the Results Screen

Any test that does not achieve the target treating speed generates a results screen. The results screen displays the following information:

- The amount of product collected during the test.
- The resulting treating speed achieved during the test.
- The target treating speed chosen during the creation of the job.
- Errors in the application of treatment that will occur if you accept the resulting treating speed.

Note

Errors only appear in two pump calibrations (see [Correct Calibration Errors on page 41](#)).

Figure 39. Example of a Results Screen

Calibration Test Result	
402 Pump 2	AaBbCcDdEeFfGgHhIi JjKkLlMmNn
Amount Collected in the Test	1234 mL
Resulting Treating Speed	123.1 %
Target Treating Speed	AaBbCcD 123.1 %
Calculated Pump 2 Error	123.1 %

Use Resulting Treating Speed	Accept Calibration Error	Try to reach Target Treating Speed
---------------------------------------	--------------------------------	---

Note

The results screen will flash invalid if outside the seed flow range.

Applying the Results

After reviewing the information on the results screen, you must decide the next action. The actions you can take vary depending on the results screen generated by the STORM software system. Keep these general principals in mind when deciding your next action:

- It is normal to perform several calibration tests before successfully collecting 1000 ml; the STORM software automatically makes adjustments to the pump speed between tests to help you achieve your target treating speed.
- In a two pump calibration, the treating speed achieved when calibrating the second pump may impact the treating speed of the first pump. The system allows you to return and re-calibrate the first pump in this case.
- If you do not achieve your target treating speed, you may accept the resulting treating speed and proceed.
- Tap **Accept Calibration Error** to continue to the treating screen without recalibrating.

8.15. Calibration Successful

When the calibration is complete, the system displays a Calibration Successful Outcome Screen. On the Calibration Successful Outcome Screen you can view the treating speed used for the job, and may proceed to calibrate a second pump, or proceed to save the job parameters and begin treatment.

Figure 40. Calibration Successful Screen

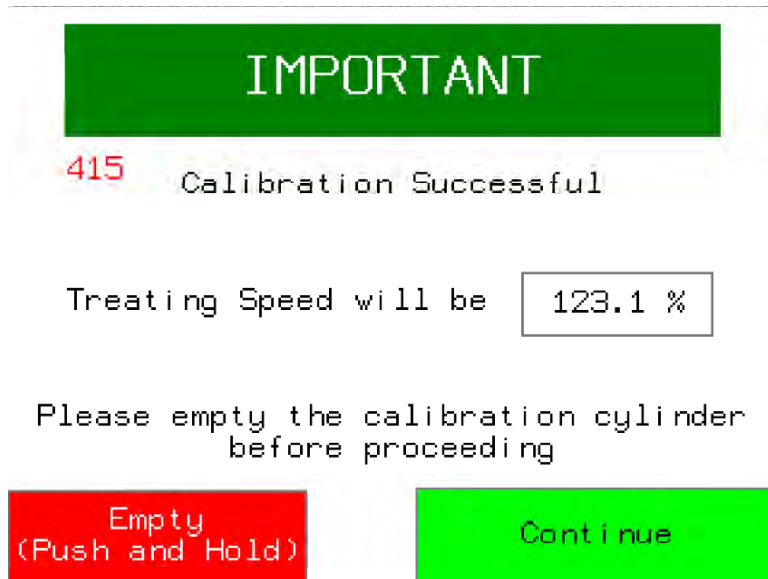

8.16. Overriding the Pump Speed Setpoint

Users who are familiar with both the product being calibrated and the STORM calibration procedure may wish to override the calculated pump speed. Adjusting the Setpoint may reduce the number of times a test needs to be performed before collecting the desired 1000 ml result.

Important

Entering a value that is higher than the generated value can result in the calibration cylinder overflowing. If the cylinder overflows, tap **Stop Test** to stop the pumps, then **Empty** to empty the cylinder. Tap **Escape Calibration** to return to the Job Screen; from the Job Screen, you may attempt to calibrate again.

Figure 41. Locating the Set-Point Field

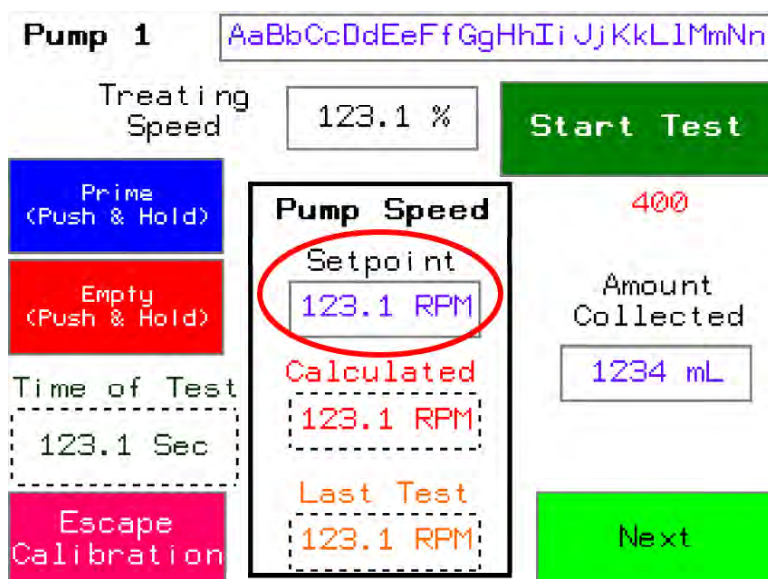

8.17. Viewing Amount of Seed Treated While Operating (Job Specific)

1. From the operation screen, tap **Seed**.
2. Toggle **Entry Amount Treated/Total Amount Treated**.
 - Entry Amount Treated shows the amount of seed treated so far for the batch in progress (in lbs and kg).
 - Total Amount Treated shows the amount of seed treated in the full history of the selected job (in lbs and kg).

Figure 42. Total Amount Treated (Seed Tab)

Job:	Test Job		
Mixer Lower Limit	Mixer Speed	Start	
	0 RPM		
Batch Size: <0 For Conf.>	0 lbs	0 kgs	
Total Amount Treated	0 lbs	0 kgs	
Seed Rate	1982 lbs/min	899 kgs/min	
Toggle Screens	Entry Amount Treated	Prime	END

8.18. Viewing Amount of Treatment Used While Operating (Job Specific)

1. From the operation screen, tap **Toggle Screens** until you view the pumps screen.
2. Toggle **Entry Amount Treated** button to **Total Amount**:
 - Entry Amount shows the amount of treatment so far applied to the batch in progress (in litres).
 - Total Amount shows the amount of treatment each pump has ever applied in the full history of the selected job (in Litres).

Figure 43. Pumps Screen

Job: Test Job			
Mixer Lower Limit	Mixer Speed	Start	
	0 RPM		
Total Amount Treatment Used	Pump 1	Pump 2	
	0.0 L	0.0 L	
Pump Rates	2922 mL/min	3372 mL/min	
Toggle Screens	Entry Amount Treated	Prime	END

8.19. Seed Flow Correction

The default value of for seed flow is 1000.

Seed flow correction represents the adjustment to treating speed made between batches by the STORM software; this adjustment occurs when there is a difference between the STORM metering system's estimated amount of seed treated and the actual amount of seed treated. The adjustment ensures that the treating speed of the job remains optimal and accurate.

The difference may be caused by:

- unique seed characteristics,
- conveyor intake conditions,
- environmental factors.

The Treating Complete Screen

When treating in batches, the system returns a screen informing you that the batch is complete. The Treating Complete screen (see [Figure 44 on page 68](#)) provides the following information:

- the job name,
- the amount of seed the system estimated will be treated based on the seed weight you defined when creating the job,
- a box for you to enter the actual amount of seed that was treated after the batch completed,
- a correction factor based on the difference between the estimated and actual amount of seed treated.

Figure 44. Treating Complete

Job:

Treating Complete!

Estimated Seed Treated

Actual Seed Treated (from Scale)

Seed Flow Correction

Note

The value in the Actual Seed Treated (from Scale) box is recorded in the job history.

Note

If you want to enter the actual amount of seed treated, you must enter it on this screen; tapping **Continue** prevents the ability to enter the actual amount of seed treated.

How Seed Flow Correction Affects Further Treating

The system automatically adjusts parameters to ensure optimum treatment the next time the job is run. It is important to recalibrate the pumps after a seed flow correction has occurred. While it is possible to treat using the system’s estimated calibration values, it is not recommended.

The system indicates that you are treating with estimated calibration values. On the Job Details screen (see [Figure 45 on page 69](#)) the system places a “9” as a prefix to the Calibration value.

Figure 45. Job Details Screen Indicating Estimated Calibration

Job:	RAXIL PRO ON WHEAT		
Pump 1	Raxil_PRO		
Application Rate	325.0 mL/100kg		
Calibration	9235.1	Error	0.0 %
Pump 2	None		
Application Rate	0.0 mL/100kg		
Calibration		Error	0.0 %
Back	ReCalibrate Pumps	Continue	

Tapping **Continue** allows you to run the batch with the estimated calibration values. The system provides a final indication that a seed flow correction has occurred with a Seed Flow Correction Warning screen (see [Figure 46 on page 69](#)).

Figure 46. Seed Flow Correction Warning

IMPORTANT

The Seed Flow Correction Value has Changed.

Selecting Continue will allow you to treat with the estimated calibration values.

Selecting Back will allow you to select Recalibrate Pumps.

Back

Continue

8.20. Flush Out

The **Flush Out** function allows the operator to set pump and the conveyor direction (forward or reverse), and specify the state (on or off) for each when **START** is pressed.

From the main menu, tap:

Maintenance — Flush Out

Set the conveyor direction (forward or reverse) and state (on or off) to reflect the conveyor action when **START** is selected.

Set the pumps direction (**Forward** or **Reverse**, to apply to both pumps) and state (on or off for each pump) to reflect the pump action when **START** is tapped.

- Tap **START** to engage the setting.
- Tap **STOP** to disengage the settings.
- Tap **BACK** to return to the maintenance screen.

Figure 47. Flush Out Menu

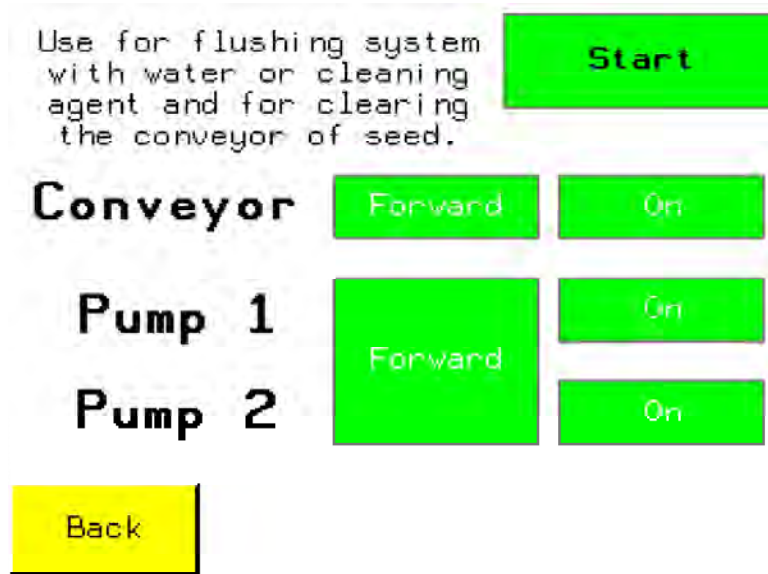

8.21. View Lifetime Total Use

Lifetime total use is the amount of time that the STORM has spent actively treating seed, and does not include the amount of time spend powered up but not treating seed.

From the main menu, tap **Maintenance**:

Figure 48. Maintenance Menu

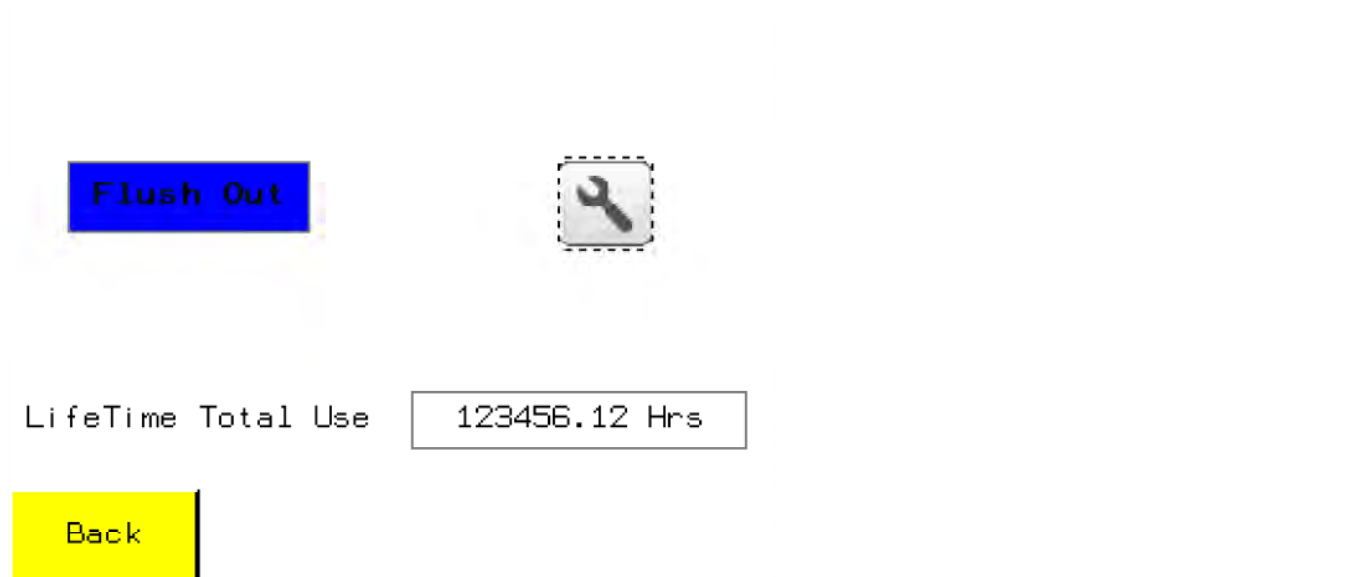

Table 8. Maintenance Menu Information

Item	Description
Lifetime Total Use	Shows the total number of hours the unit has actively treated seeds (0-999999 h) since the software was last updated.

Note

Record the value displayed in the Lifetime Total Use field before updating the software; the value is set to zero when the software is updated.

8.22. View Diagnostics

- **Pre-operational diagnostics** can be viewed before operating the system, and are used to verify that the conveyor and pumps are reporting adequate supply voltages before a job is running.
- **Operational diagnostics** are viewed while a job is running, and can be used to determine if the overall system performance is adequate by providing information related to system performance under operational load.

To view pre-operational diagnostics, from the main menu tap:

Maintenance — 

To view operational diagnostics, tap **Toggle Screens** to cycle between operation screens.

Figure 49. Pre-Operational Diagnostics Screens

Item	Description
Mains voltage conveyor	The voltage supply measured at the conveyor. Should be between 210 and 240 VAC.
Mains voltage Pump 1	The voltage supply measured at the Pump 1 motor. Should be between 210 and 240 VAC.
Mains voltage Pump 2	The voltage supply measured at the Pump 2 motor. Should be between 210 and 240 VAC.
Conveyor status	Conveyor motor status.
Pump 1 status	Pump 1 motor status.
Pump 2 status	Pump 2 motor status.

Important

The status displayed for the conveyor and pumps must end in a “1”; if the status differs, consult a service technician.

Table 9. Operational Diagnostics Screens

Item	Description
Conveyor	Conveyor speed (belt RPM).
Conveyor Motor	Conveyor motor speed (RPM).

Table 9 Operational Diagnostics Screens (continued)

Item	Description
Pump 1	Pump 1 motor speed (RPM).
Pump 2	Pump 2 motor speed (RPM).
Mains Voltage	Supply voltage, as detected by the control box. Should be between 210 VAC and 240 VAC while motors are running under load.
Total Amps	Total system power draw, as measured by the control box (Amps).

8.23. Alarms

The alarms screen displays the last six control box errors, listed with the newest alarm on the top of the list. When the list is full, the oldest alarm entry is erased as a new alarm is recorded.

Viewing Alarms

To view Alarms, tap **Alarms** from the main menu.

Figure 50. Alarms Screen



Alarms are service-affecting, and interrupt operator activity with an error screen. The last six alarms are displayed on the Alarm History screen. The unit will not run with an alarm. Correcting an alarm does not remove it from the Alarm History Screen. To attempt to correct an alarm, see the alarm descriptions in [Table 10 on page 73](#), and follow any instructions, including those provided on the STORM display. Be prepared to contact an AGI service professional as required.

Figure 51. Alarms Declaration Screens**Table 10. Alarm Descriptions**

Alarm #	Error	Controller Display (AGI Service Only)	What it means	Action(s)
5	ModBus Communication Error ¹	SLF1	HMI is unable to communicate with motor controller(s).	Reboot Controller. Unplug the Control Box and wait for 30 seconds before plugging back in.
9	OverCurrent Error ²	OCF	Motor is drawing too much current. Motor is overloaded.	Let unit cool down. Reduce load by lowering treating speeds if problem persists.
16	Drive Over-Heat Error ³	OHF	Motor Controller has overheated.	Let unit cool down. Reduce load by lowering treating speeds if problem persists.
17	Motor OverLoad Error ⁴	OLF	Motor is overloaded.	Let unit cool down. Reduce load by lowering treating speeds if problem persists.
19	Mains OverVoltage Error	OSF	Input Voltage Fault. Input voltage exceeds 240 Volt limit.	Check power supply. If using a generator check for an over-speed condition.
20 or 33	Output Phase Loss Error	OPF1 OPF2	Loose Wire on the output side of the motor controller.	Check motor electrical connections. Check motor supply cables for damage. If problem persists, contact an AGI Service Specialist.
21	Input Phase Loss Error	PHF	Loss of Input power.	If problem persists, contact an AGI Service Specialist.
22	UnderVoltage Error	USF	Input Voltage Fault - voltage too low. Power source inadequate.	Check power source. Source unable to provide adequate power. Supply cable exceeds recommended maximum length or gauge too high. Power source is not dedicated to STORM.

Table 10 Alarm Descriptions (continued)

23 or 56	Motor Short Circuit Error	SCF1 or SCF5	Motor Shorted. Could be caused by a loose wire or a motor failure.	Check for loose wiring at motor. Replace motor if failed.
25	AutoTuning Error	tnF	Controller did not initialize properly.	Reboot Controller. Unplug the Control Box and wait for 30 seconds before plugging back in.
32	Circuit Shorted to Ground Error	SCF3	Supply wires to the motors shorted.	Check motor electrical connections. Check motor supply cables for damage. If problem persists, contact an AGI Service Specialist.

1. Often occurs when control box is not powered down for 30 seconds after a software upload.
2. May occur if conveyor or pumps have excessive drag.
3. May occur if conveyor or pumps have excessive drag.
4. May occur if conveyor or pumps have excessive drag.

9. Maintenance



Before continuing, ensure you have completely read and understood this manual's Safety section, in addition to the safety information in the section(s) below.

9.1. Maintenance Safety

WARNING

- Keep components in good condition. Follow the maintenance procedures.
- Ensure the service area is clean, dry, and has sufficient lighting.
- Do not modify any components without written authorization from the manufacturer. Modification can be dangerous and result in serious injuries.
- Shut down and lock out power before maintaining equipment.
- After maintenance is complete, replace all guards, service doors, and/or covers.
- Use only genuine STORM replacement parts or equivalent. Use of unauthorized parts will void warranty. If in doubt, contact STORM or your local dealer.



Before attempting maintenance of any kind:

- Lower the seed treater fully.
- Chock wheels.
- Support tube if performing maintenance on the undercarriage assembly.
- **If equipped with hydraulics:** Before applying pressure to a hydraulic system, make sure all components are tight and that hoses and couplings are in good condition.

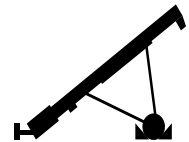

9.2. Maintenance Schedule

Proper maintenance habits mean a longer life, better efficiency, and safer operation. Please follow the Maintenance Schedule below. Keep good records of the hours the seed treater has been operated and the maintenance performed.

For Maintenance of the gas engine, consult the engine Operator's Manual.

Item	Pre-Season	Daily	Weekly	Two Weeks	Yearly (or end of Season)	As Required
Section 9.3 – Visually Inspect the Seed Treater on page 77	X	X			X	
Section 9.16 – Check and Replace the Pump’s Chemical Hoses on page 83	X					
Section 9.14 – Check and Maintain the Containment System on page 82	X			X		
Section 9.9 – Check the Chemical Pump Rollers on page 80	X					
Section 9.7 – Clean and Coat the Calibration Cylinders on page 78	X	X				
Section 9.8 – Clean the Mixing Boot and Chemical Hoses on page 79		X				
Section 9.15 – Advanced Mixer Clean-Out on page 83		X				
Section 9.13 – Clean the Conveyor Belt on page 82		X				
Section 9.10 – Clean the Filter Strainers on page 80		X				
Section 9.12 – Drain Antifreeze from the System on page 81	X					
Section 9.11 – Fill the System with Antifreeze on page 81					X	
Section 9.4 – Grease the Bearings on page 77	X				X	
Section 9.5 – Check the Gearbox Oil on page 78					X	
Section 9.6 – Change the Gearbox Oil on page 78	X					X
Section 9.17 – Inspect/Replace the Conveyor Rollers and Bearings on page 84	X					
Section 9.18 – Tension the Conveyor Belt on page 85	X					
Section 9.19 – Align the Conveyor Belt on page 86	X					
Section 9.23 – Clean and Wash the Equipment on page 89	X	X			X	
Section 9.20 – Tension the Drive Belts on page 88	X					
Section 9.21 – Align the Drive Belts on page 88	X					
Section 9.22 – Replace the Drive Belts on page 89						X
Section 9.24 – Inspect Belt Lacing on page 89	X					
Section 9.25 – Replace the Belt Lacing on page 89						X

Item	Pre-Season	Daily	Weekly	Two Weeks	Yearly (or end of Season)	As Required
Section 9.26 – Replace the Conveyor Belt on page 90						X
Section 9.27 – Inspect and Service the Hand Winch and Lift Cable on page 91						X
Section 9.28 – Inspect and Service the Hydraulic Winch and Lift Cable on page 92						X
Section 9.29 – Adjust the Mover Kit Ram and Travel Speed on page 92						X
Section 9.30 – Pinion Gear Adjustment on page 93						X
Section 9.31 – Change the Hydraulic Oil on page 94						X
Section 9.32 – Remove / Replace the Shear Bolt on page 94						X

9.3. Visually Inspect the Seed Treater

 **WARNING** Lock out power before inspecting.

Check the following during a visual inspection:

1. Ensure all guards are in place and in good working order.
2. Examine the seed treater for damage or unusual wear.
3. Check tightness of bolts/nuts, fasteners, and hardware (re-torque if necessary).
4. Be sure all safety decals are in place and are legible.
5. Check that the discharge and intake area are free of obstructions.
6. Inspect all moving or rotating parts to see if anything has become entangled in them. Remove any entangled material.
7. Inspect hydraulic hoses and fittings for leaks and wear. Fix or replace where necessary.
8. Check wheel bolts are tight and examine tires for gashes, uneven wear, or loss of air pressure. See [Section 12. – Specifications on page 108](#) for recommended tire pressure and torque information.
9. Check all operating, lifting, and transport components. Replace damaged or worn parts before using the seed treater.
10. Make sure access, service, and cleanout covers are in place and secure.

9.4. Grease the Bearings

To keep the system operating effectively, check all grease points and ensure that they are sufficiently well greased.

Refer to [Section 12. – Specifications on page 108](#) for grease and oil types.

Figure 52. Greasing Locations

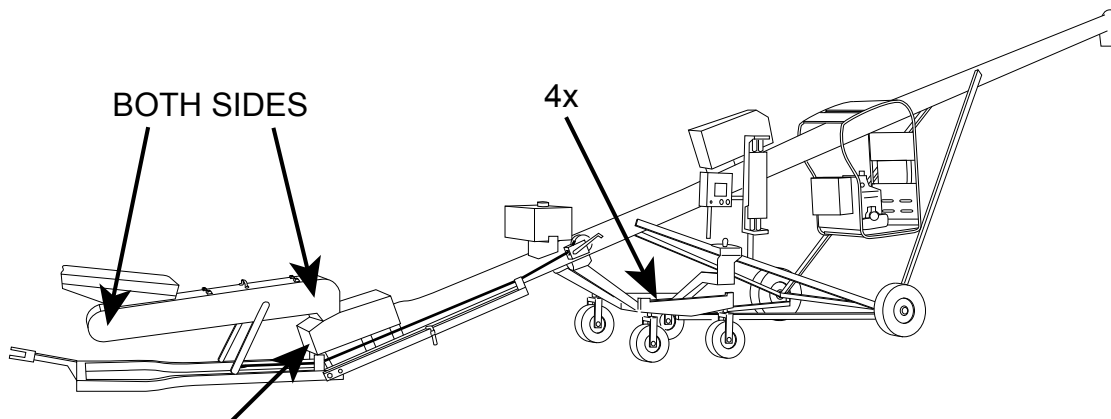

9.5. Check the Gearbox Oil

1. Remove fill/vent plug to check gearbox oil level. Insert an improvised dipstick (rolled paper or plastic tie) into the oil filler hole to determine the oil level.
2. Note the level and the condition of the oil. Maintain oil level at half full (center of cross shaft) with 90W or equivalent gear oil, adding as necessary or drain and refill if condition is poor.
3. Ensure gearbox is level when checking or refilling.
4. Do not overfill when adding oil.
5. Replace fill/vent plug.

9.6. Change the Gearbox Oil

Use SAE approved 90W or equivalent gear oil.

1. Remove gearbox from the seed treater.
2. Place a pan under the drain plug.
3. Use a wrench and remove the drain plug.
4. Loosen the filler plug so air can enter the gearbox and the oil will drain freely.
5. Allow the oil to drain completely.
6. Replace the drain plug.
7. Add oil until the gearbox is half full (center of cross shaft) and replace filler plug. A flexible funnel may be required. Gearbox should be level when checking or refilling. **Do not overfill.**
8. Reinstall the gearbox and guards.

9.7. Clean and Coat the Calibration Cylinders

Clean and coat the calibration cylinders whenever the level of treatment becomes difficult to read.

1. Loosen the two bolts (1) directly alongside of the calibration cylinder.
2. Slide the bracket (2) apart.
3. Loosen the hose clamp (3) located at the top of the calibration cylinder.
4. Pull the wiper handle (4) up until the wiper is out of the cylinder.
5. Loosen the hose clamp (5) located at the bottom of the cylinder.
6. Remove the calibration cylinder (6).
7. Scrub the cylinder with a disposable rag and flush with water.

Note

Follow the manufacturers' instructions on disposal of waste water.

8. Put the calibration cylinder back in place then secure hose clamps.
9. Put the wipers, clamps, and associated hardware back in place.

Figure 53. Lubricating the Calibration Chamber

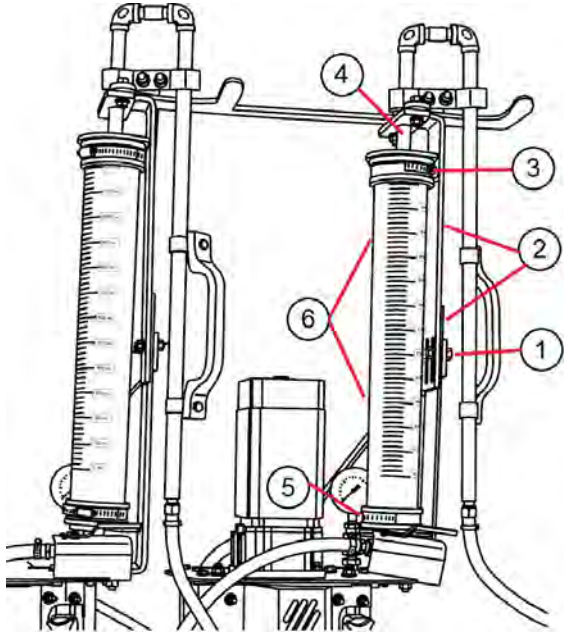

Item	Description
1	Bolt
2	Cylinder bracket
3	Hose clamp
4	Wiper handle
5	Hose clamp
6	Calibration cylinder

9.8. Clean the Mixing Boot and Chemical Hoses

After operating the seed treater, thoroughly clean the system to ensure efficient operation for the next treating application.



Refer to 2.7 Seed Treatment Safety, page 10 for information on safe disposal of contaminated rinse water.

Use the Flush Out function on the system maintenance screen.

1. Place the seed treater in the clean-out position. Place a container under the seed treater to catch runoff.
2. Open all clean-out doors and covers.

3. Use the system pumps to run water to flush the hoses and clean out the mixing boot.
4. Use an additional water hose to flush out the mixing boot.

Figure 54. Clean-Out Position

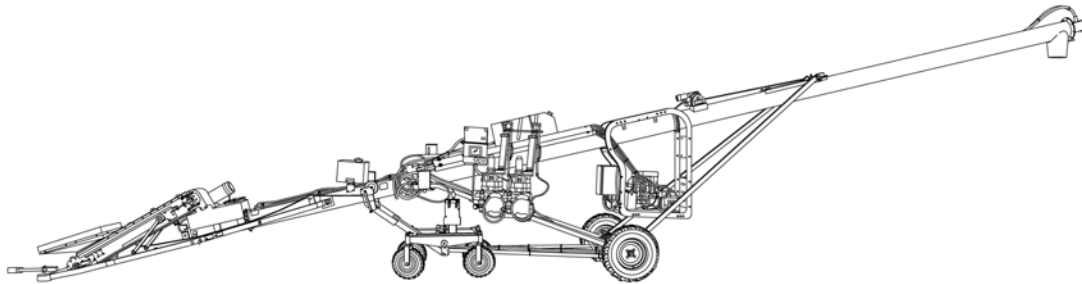

9.9. Check the Chemical Pump Rollers

1. Open the covers and confirm the pump rollers move freely.

Figure 55. Chemical Pump Rollers

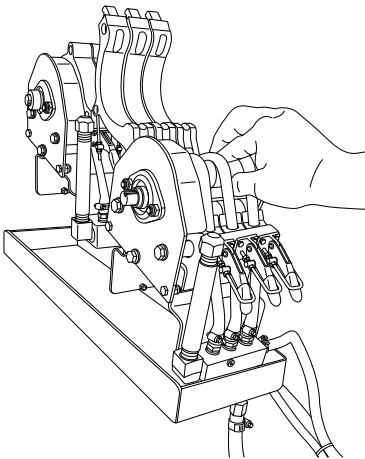

9.10. Clean the Filter Strainers

1. Unscrew the cap and rinse residue from strainer and replace. Replace the cartridge if it is damaged.

Note

Watch for the rubber seal that seals the cup to the body, it can get lost easily when cleaning.

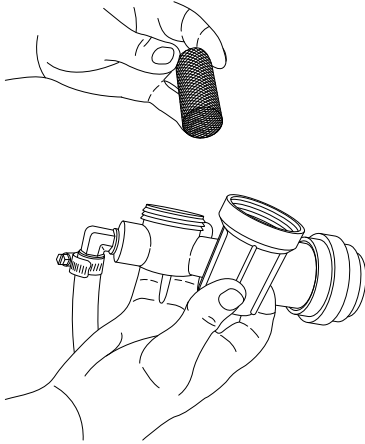
Figure 56. Strainer

9.11. Fill the System with Antifreeze

At the end of each treating season, fill the chemical hoses with antifreeze to keep them in good condition.

Use the Flush Out function on the system maintenance screen.

1. Place hose ends in antifreeze.
2. Turn the pumps on.
3. Set ball valves to calibrate.
4. Coat calibration cylinders with antifreeze.
5. Drain antifreeze.
6. Set ball valves to treat.
7. Run antifreeze through the system.
8. Cover calibration tubes with a waterproof tarpaulin when not in use.

9.12. Drain Antifreeze from the System

At the start of each treating season, drain antifreeze by flushing the Pumps, Hoses, Filters, and Coupler. Run the pumps until clear.

Use the Flush Out function on the system maintenance screen.

1. Drain and collect antifreeze from treatment lines and filters.
2. Store the antifreeze for further use or dispose of safely.
3. Flush all hoses and lines with water, and dispose of rinse-water safely (it will contain anti-freeze).
4. Ensure pump shoes are closed.
5. Run pumps forward and backward, and check for any unusual noise or actions.

9.13. Clean the Conveyor Belt

1. Remove the conveyor covers.
2. Position the conveyor in clean out position, see [Figure 57](#).
3. Remove the bottom covers.
4. Inspect the belt for a build-up of treatment residue.
5. Use a high-pressure washer to remove excessive treatment residue.

Figure 57. Clean-Out Position

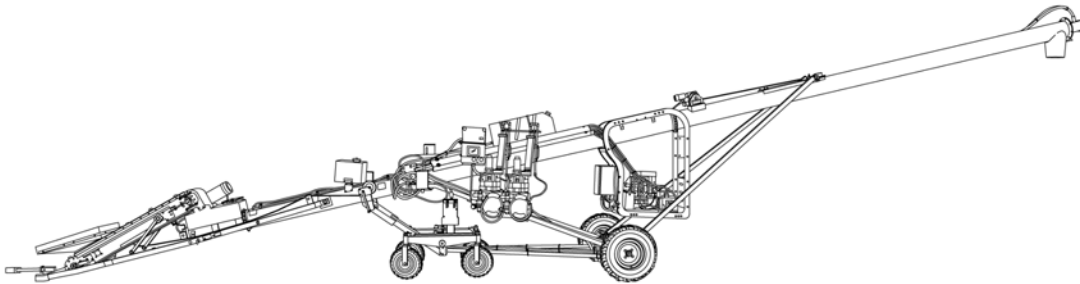

9.14. Check and Maintain the Containment System

Chemical Hoses

Ensure nothing is caught in the hoses, if there is, flush out with water or replace the line if necessary.

Fittings

Check for leaks at intake filters and other connection points, replace if cracked or worn.

Back Clean-out Door Seal

Make sure the neoprene seal is in good condition, replace if damaged.

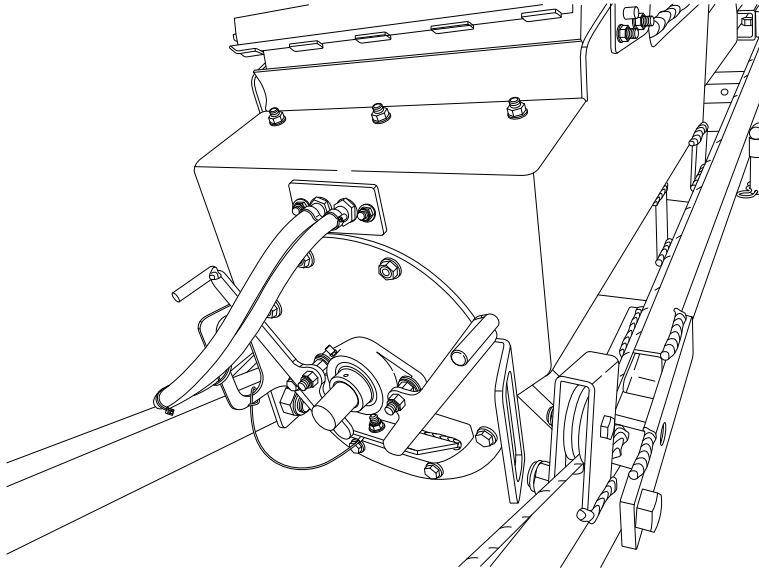
Figure 58. Back Clean-out Door Seal

9.15. Advanced Mixer Clean-Out

Complete this procedure daily or more often as required to keep the seed treater operating effectively.

1. Position the seed treater with the mover controls to allow for the full extraction of the mixer flighting with the mixer tube at a low angle, boot slightly raised, and conveyor intake at full height.
2. Lockout power to the mixer.
3. Remove the bolt at the mixer discharge.
4. Remove bolts holding bottom mixer bearing plate.
5. Pull the mixer flighting out.
6. Clean with compressed air or water.
7. Reassemble.

9.16. Check and Replace the Pump's Chemical Hoses

To prevent chemical leaks/spills, change pump the tubing annually or if there are kinks, wear, or leaks.

For hose type, refer to [Section 12. – Specifications on page 108.](#)

To replace the pump's chemical hoses:

1. Remove clamps and hoses.
2. Check the length of the new hose is identical to the hose being replaced.

Important

Replacement hoses must be identical in type and length or the pump may not operate correctly.

3. Slide the new hoses on and reconnect the clamps.

Note

Use rubbing alcohol or soapy water to aid in getting hoses on.

9.16.1 Pump Tubing Break-In

The pump tubing elements require a minimum 30 minute break-in period in order to meter consistently. If proper break-in is not performed, the system will not calibrate correctly.

This procedure must be repeated each time that pump tubing is changed.

For each new pump tubing element:

1. Set the valves to the calibration positions for the pump.
2. Ensure the cylinder is clamped tightly in the bracket and that the top plug is fully inserted in the top of the cylinder.
3. Connect a male coupler to the dry-break coupler of the associated pump, and place the couplers in a suitably large-volume container of water.
4. Route the overflow tube found at the top of the calibration cylinder into the water container. Ensure the tube is fully inserted into the black cap found at the top of the calibration cylinder.
5. On the touch screen, select Flush Out from the Maintenance screen.
6. Ensure that the pump with the tubing element that is intended for break-in is set to On and in the Forward direction.
7. Ensure that the pump with the tubing not intended for break-in is set to Off.
8. Press Start and run the pump for a minimum of 30 minutes circulating water the entire time.

9.17. Inspect/Replace the Conveyor Rollers and Bearings

Inspecting the Conveyor Rollers and Bearings

To inspect the rollers, listen for the belt slipping (squealing sound) from the drive roller on the conveyor.

NOTICE

Operating the conveyor with a damaged roller will result in a damaged conveyor belt.

Check the roller bearings for wear. Any rollers making noise, getting hot while running, or that give should be replaced.

Replacing a Conveyor Roller and Bearing

1. Remove and replace the components as shown in [Figure 59](#)

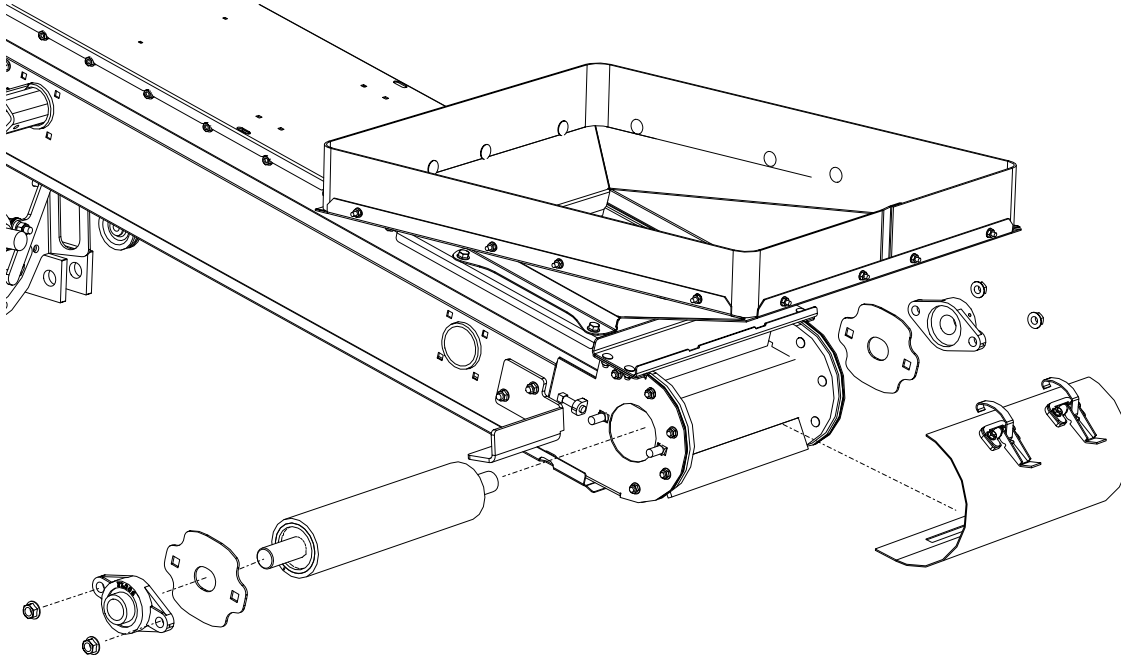
Figure 59. Replacing a Conveyor Roller

9.18. Tension the Conveyor Belt

Adjusting your conveyor belt for proper tension helps to ensure trouble-free operation and long belt life.

Ensure the belt is thoroughly clean prior to tensioning or aligning the belt. Foreign materials may affect tension and alignment. Refer to [Section 9.13 – Clean the Conveyor Belt on page 82](#).

The conveyor belt only needs to be tight enough to not slip on the drive roller. If the belt is too loose, it will slip on the drive roller making a noticeable sound, slowing the belt down. The conveyor belt should pull roughly level with the conveyor side channel with 5–10lb of force, otherwise the belt will require tensioning, or loosening from being too tight.

NOTICE

Failure to stop using a conveyor with a slipping belt will damage it and/or the drive roller lagging. In extreme cases, sections of burnt belt will have to be replaced. This type of damage is not covered by warranty.

To set correct conveyor belt tension:

1. Loosen the bearing bolts and jam nut at the spout roller, see [Figure 60 on page 86](#).
2. Tighten the tightener bolts equally, use a tape measure to verify. The conveyor belt should deflect 1-2" when pushed down with a 5 lb force, or be difficult to pull from the sides of hopper transition.
3. Tighten the bearing bolts and jam nut (if included).
4. Ensure the hopper roller is tensioned equally by using a tape measure to check both sides.
5. Check the belt tension by running the conveyor for one minute. If the conveyor belt is not slipping, then proceed to next step; otherwise repeat from step 1.
6. After the conveyor belt has been tensioned, check the alignment of all rollers, see [Section 9.19 – Align the Conveyor Belt on page 86](#).
7. If the conveyor belt is still loose after tensioning, the belt needs to be replaced (depending on wear).

Figure 60. Conveyor Hopper

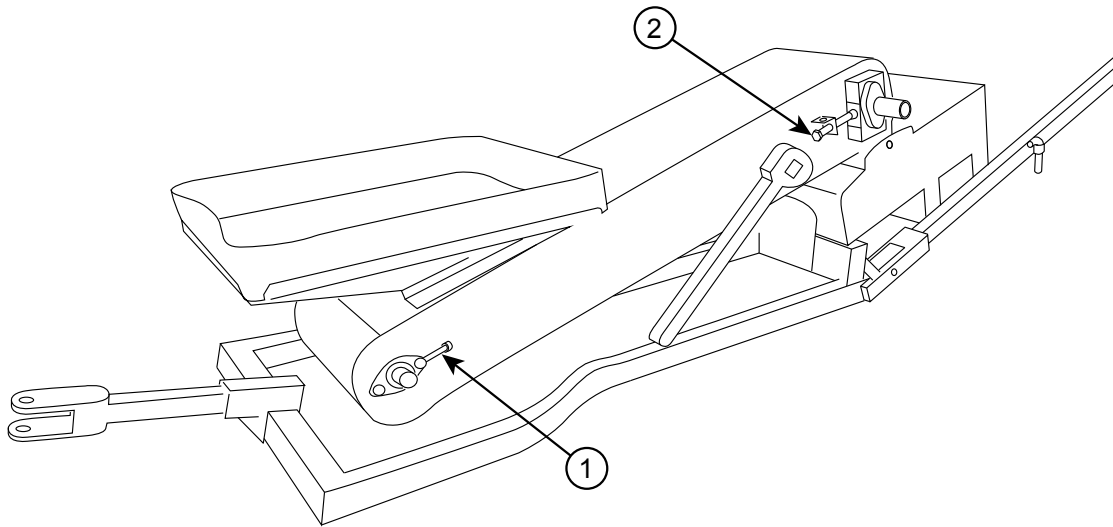

Table 11. Main Components

Item	Description	Item	Description
1	Adjustment Bolt (Belt Alignment)	2	Tightener Bolt (Belt Tension)

9.19. Align the Conveyor Belt

Basic Conveyor Belt Alignment:

The conveyor belt will run straight when all of the rollers are straight.

Loosen or tighten the adjustment bolt(s) to align the conveyor belt. Tighten the side the belt has moved toward, or loosen the side the belt has moved away from.

Figure 61. Roller out of Alignment

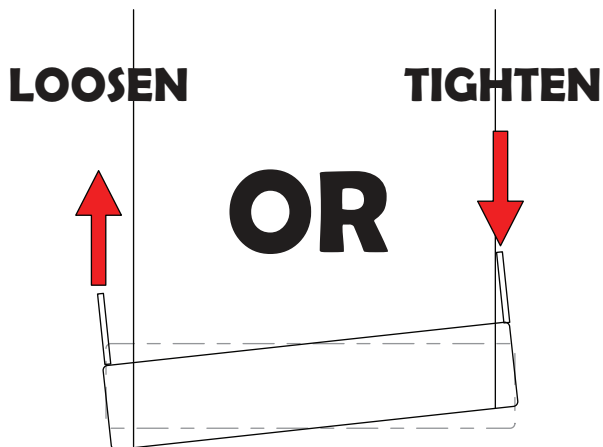

Before Aligning the Belt:

- The conveyor must be empty of all grain.

- Wait until the belt makes a complete revolution before adjusting the rollers. Some belts may have uneven edges, appearing misaligned.

To Align the Belt:

If your belt is tracking off-center, follow the sections and steps in the order following to center it.

Figure 62. Belt Tracking to One Side

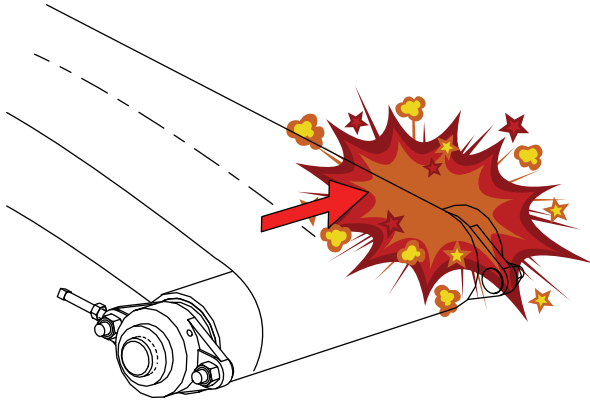

9.19.1 Adjust the Rollers

1. Loosen bearing nuts and jam nuts (if equipped).

Figure 63. Loosen the Bearing Nuts

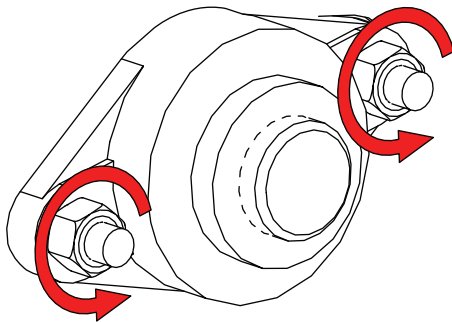

2. Rotate adjustment bolt 1/2 turn.

Figure 64. Rotate the Adjustment Bolt

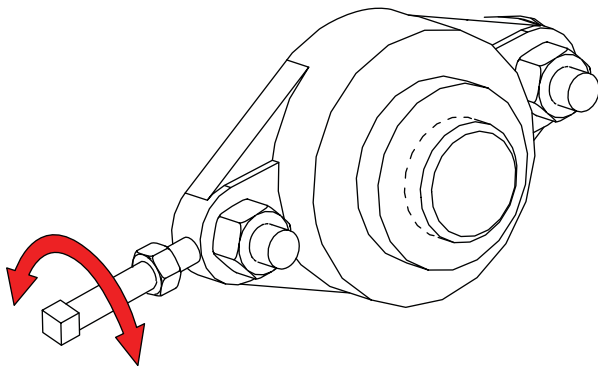

3. Restart conveyor and run empty for 1 minute.

4. Stop the conveyor and remove ignition key or lock out the power source.
5. If the belt has centered, move to next step. If not, repeat Step 2 to Step 4 until the belt is centered.
6. Tighten the bearing bolts and jam nut (if equipped).
7. Replace any guards that were removed.

9.20. Tension the Drive Belts

➡ When equipped:

1. Remove guard and push on the center of the belt span with a force of approximately 5 lb. The belts will deflect approximately 1" (25 mm) when properly tensioned.

Figure 65. Typical Drive Belt Tensioning

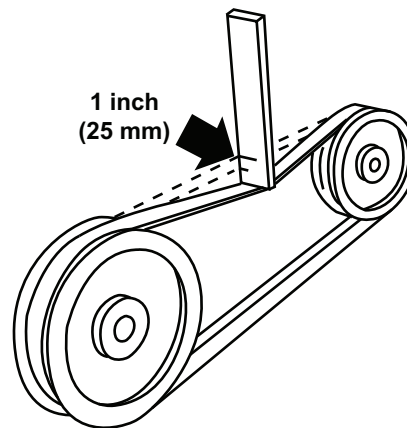

2. Tighten or loosen the drive belts (or idler pulley when equipped) to achieve the proper tension.

Important

The drive belt should be just tight enough to not slip on the drive pulley when operating. If the belt is too loose, it will slip, possibly causing a squeaking sound and slowing the belt down. If the belt is too tight, it will cause excess wear.

3. Reattach and secure guard. Start system to ensure proper operation.

9.21. Align the Drive Belts

➡ When equipped:

1. Lay a straight edge across the pulley faces to check the alignment.
2. Use the pulley hub to move the pulley to the required position for alignment.
3. Tighten the hub bolts to secure pulley on the drive shaft.
4. Check the belt tension.
5. Reattach and secure the guard.

9.22. Replace the Drive Belts

➡ When equipped:

1. Remove the guard.
2. Fully loosen the drive belts.
3. Remove and replace the old belts.
4. Tighten the drive belts as described in Belt Tension.
5. Align the drive belts as described in Belt Alignment.
6. Reattach and secure the guard.

9.23. Clean and Wash the Equipment

1. Clean out excess grain from all areas of the seed treater.
2. Make sure water can drain from the seed treater tube and intake, then wash the tube with a water hose or pressure washer until all dirt, mud, debris, or residue is gone.

Important

Do not contact electronic controls with high pressure washer.

3. Provide sufficient time for the water to drain from the seed treater.

9.24. Inspect Belt Lacing

Inspect the condition of the belt lacing, if any clips are worn through, replace all lacing.

9.25. Replace the Belt Lacing

1. Remove the conveyor cover and rotate the conveyor belt until the lacing is by the hopper or is easily accessible.
2. Loosen the conveyor belt and remove the lacing retainer clip and pin.
3. Using a square and sharp knife, cut the lacing off right behind the lacing clips. The cut belt **MUST** have a square end.
4. Use a lacing tool to install new lacing clips. Lacing clips are one clip shorter than the belt width. For example: the lacing for a 15" wide belt is 14 clips. Center the lacing on the belt and install the lacing as per instructions on the lacing tool.
5. Reattach the conveyor belt ends together. If required, use a ratchet strap clamped to both ends of the belt to cinch the belting ends together. [Figure 66 on page 90.](#)
6. Install the lacing pin and crimp the retainer clips onto each end of the lacing pin. [Figure 67 on page 91.](#)
7. Remove the ratchet strap and tighten the conveyor belt, see [Section 9.18 – Tension the Conveyor Belt on page 85.](#)
8. Check and set the belt alignment, see [Section 9.19 – Align the Conveyor Belt on page 86.](#)

- Engage the conveyor drive. Allow the conveyor to run for 30 seconds, then shut down the conveyor and inspect the lacing.

9.26. Replace the Conveyor Belt

- Remove the conveyor cover and rotate the conveyor belt until the lacing is by the hopper or is easily accessible.
- Move the tension roller to its loosest position.
- Pull all the slack to the lacing area.
- Remove the lacing retainer clip and pin.
- Attach one end of the replacement belt to the belt end being removed, closest to the hopper.
- Pull the old belt out and the new belt will be threaded into place.
- Disconnect the old belt.
- Reattach conveyor belt ends together. If required, use a ratchet strap clamped to both ends of belt to cinch belting ends together. [Figure 66 on page 90.](#)

Figure 66. Using the Ratchet Strap

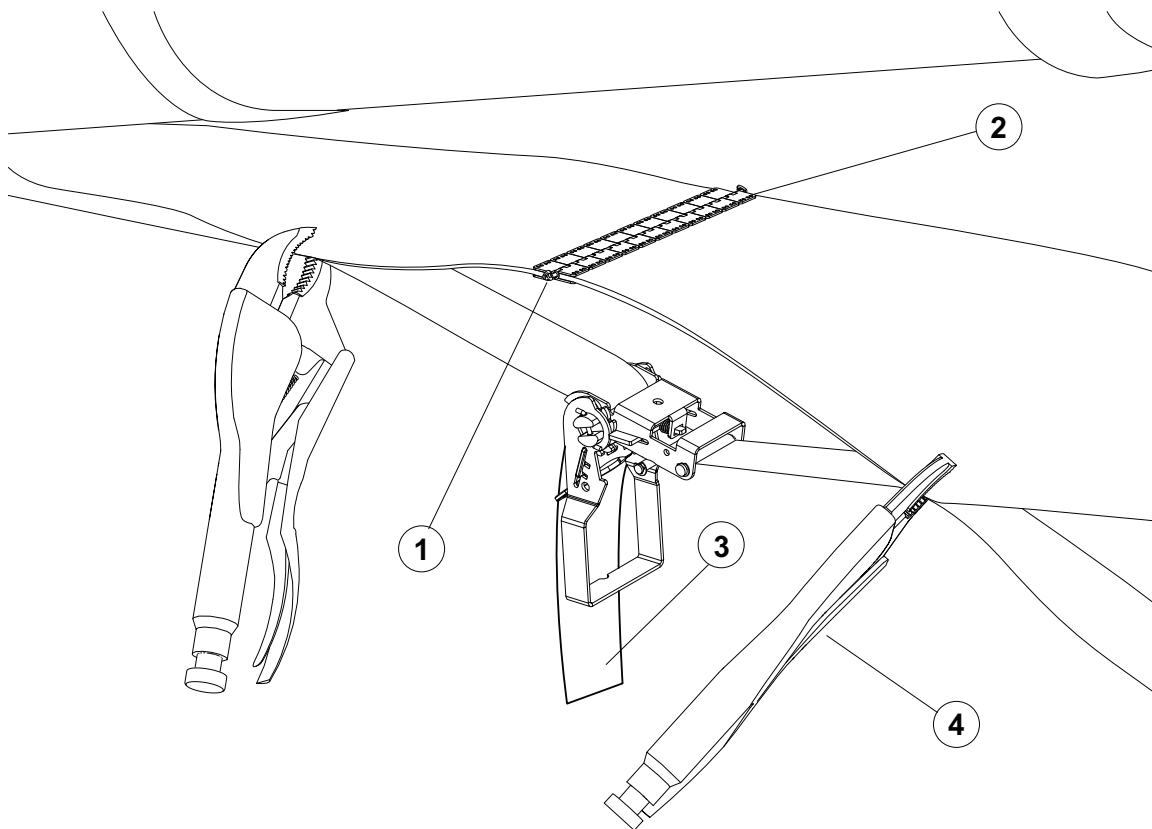

- Install the lacing pin and crimp the retainer clips onto each end of the lacing pin, see [Section 9.25 – Replace the Belt Lacing on page 89.](#)
- Remove the ratchet strap and tighten the conveyor belt, see [Section 9.18 – Tension the Conveyor Belt on page 85.](#)
- Check and set the belt alignment, see [Section 9.19 – Align the Conveyor Belt on page 86.](#)

- Engage the conveyor drive. Allow it to run for 30 seconds, then shut down the conveyor and inspect the lacing.

Figure 67. Lacing the Conveyor Belt

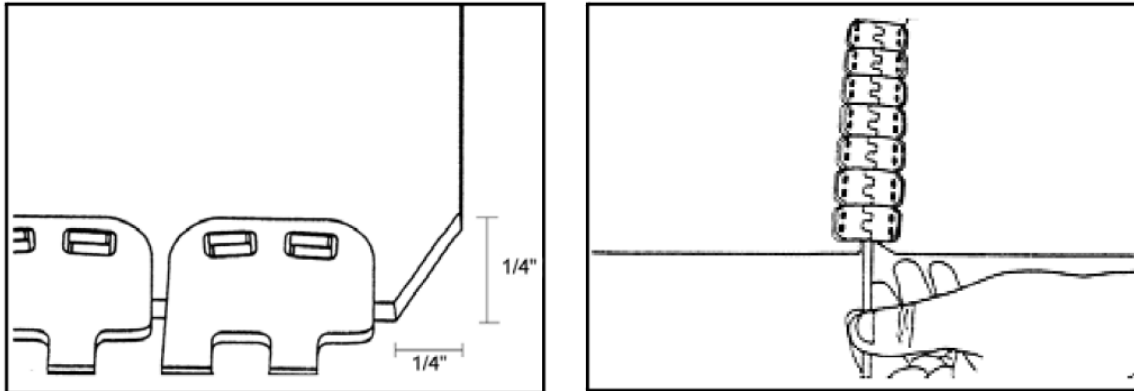

9.27. Inspect and Service the Hand Winch and Lift Cable

➔ When equipped:

⚠ WARNING Place seed treater in fully lowered position with cable slack.

- Inspect the cable for damage such as fraying, kinking, or unwinding. Replace if damaged (see below).
- Check to make sure cable clamps are secure.
- Oil cable pulleys as needed.
- Keep a film of grease on the gears. Occasionally oil the bushings, drum shaft, and ratchet.
- Do not get oil or grease on brake discs.
- Replace brake discs if less than 1/16" (1.6 mm) thick.
- Check for proper ratchet pawl operation:
 - When cranking in (clockwise) = loud clicking
 - When cranking out (counterclockwise) = no clicking and ratchet pawl fully engaged into gear teeth.

To Replace the Lift Cable:

- Unwind the winch drum until cable is slack and remove all cable clamps.
- Free the cable from the winch and pulleys.
- Remove the cable clamps that secure the hook in place.
- Reverse the above steps to install the new cable.

9.28. Inspect and Service the Hydraulic Winch and Lift Cable

 **WARNING** Place the seed treater in the fully lowered position with the cable slack.

To Inspect the Lift Cable:

1. Inspect the cable for damage such as fraying, kinking, or unwinding. Replace if damaged (see below).
2. Check to make sure the cable clamps are secure.
3. Oil the cable pulleys as needed.
4. Occasionally oil the bushings and drum shaft.

To Replace the Lift Cable:

1. Unwind the winch drum until the cable is slack and remove the cable clamps.
2. Free the cable from the winch and pulleys.
3. Remove the cable clamps that secure the hook in place.
4. Reverse the above steps to install the new cable.

9.29. Adjust the Mover Kit Ram and Travel Speed

 When Equipped:

 **WARNING** Place the machine on level surface and fully lower the intake and discharge ends. Ensure the engine is in idle and the seed treater drive is disengaged before adjusting.

Hydraulic Pressure Adjustment

If the controls are "jerky" or act too fast, it may be necessary to adjust the hydraulic pressure on the wheel move. To do this, follow the steps below and refer to [Figure 68 on page 93](#).

1. **To decrease hydraulic pressure:** Loosen the nut on the three spool valve (bottom right side of valve) and turn the adjustment screw out (counter-clockwise). Tighten the nut.
2. **To increase hydraulic pressure:** Loosen the nut on the three spool valve (bottom right side of valve) and turn the adjustment screw in (clockwise). Tighten the nut.

RAM Speed Adjustment

Ram speed in each direction of travel is regulated at the control valve. Adjust the stroke limiter screws and jam nuts until the desired rate of travel is achieved.

- Turning the screws inward results in a slower speed.
- Turning the screws outward results in a faster speed.

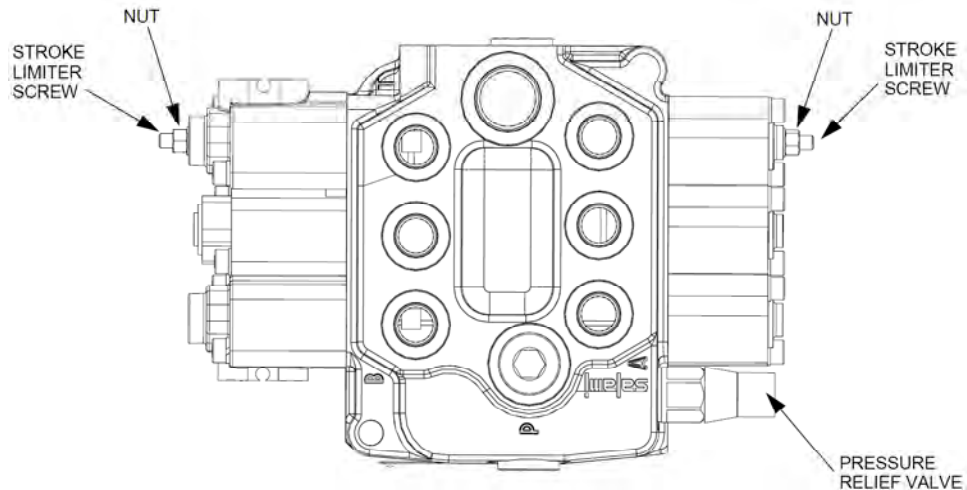
Figure 68. Control Valve Adjustment**Travel Speed Adjustment**

To control the speed of the mover, the cushion valve can be adjusted:

- screwed in for increased speed.
- screwed out for decreased speed.

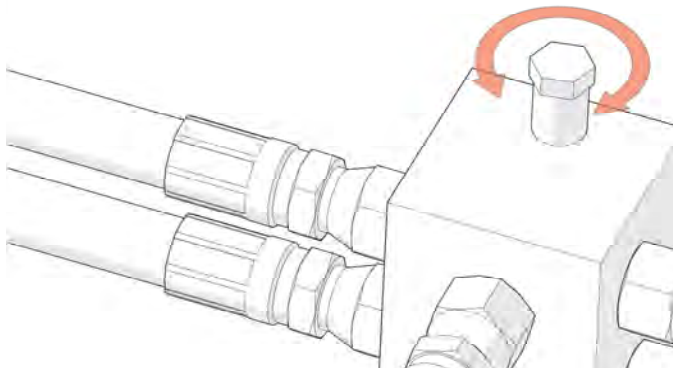
Figure 69. Cushion Valve Adjustment**9.30. Pinion Gear Adjustment**

➡ When Equipped:

The pinion gear should mesh with the ring gear to provide maximum tooth contact. If the pinion gear does not mesh entirely with the ring gear:

1. Adjust the handle slot bolt (which bolts to the drive mount clamp) so full meshing of the pinion gear is achieved when the handle is in the over-center position. The pinion gear will need adjustment when gear teeth bind or are not meshing sufficiently.
 - **Gear teeth binding:** If the handle will not lock into over-center position, loosen the slot bolt nuts and slide the handle away from the tire.

- **Insufficient Meshing:** If the pinion gear will barely mesh with the ring gear, loosen the slot bolt jam nuts and slide the handle towards the tire until the pinion gear teeth mesh with the ring gear teeth without binding.

Figure 70. Pinion Gear Adjustment Nut

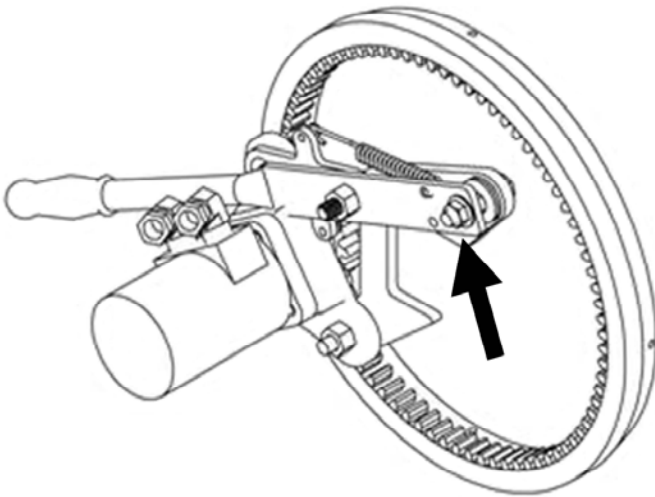

9.31. Change the Hydraulic Oil

Change the hydraulic oil to remove any accumulation of dirt or condensation in the system. Do not over-fill the reservoir. Leave space to allow for level fluctuation. Refer to [Section 12. – Specifications on page 108](#) for oil type.

9.32. Remove / Replace the Shear Bolt

1. Position the seed treater with the mover controls to allow for the full extraction of the mixer flighting with the mixer tube at a low angle, boot slightly raised, and conveyor intake at full height. Lock ball valves to secure the seed treater.
2. Lockout power to the mixer.
3. Locate and remove / replace the shear bolt (1) through the discharge spout of the mixer tube.

Note

There is only one 3/8" x 2-1/2" hex bolt (GR 8) and 3/8" locknut in this position.

Figure 71. Removing the Shear Bolt

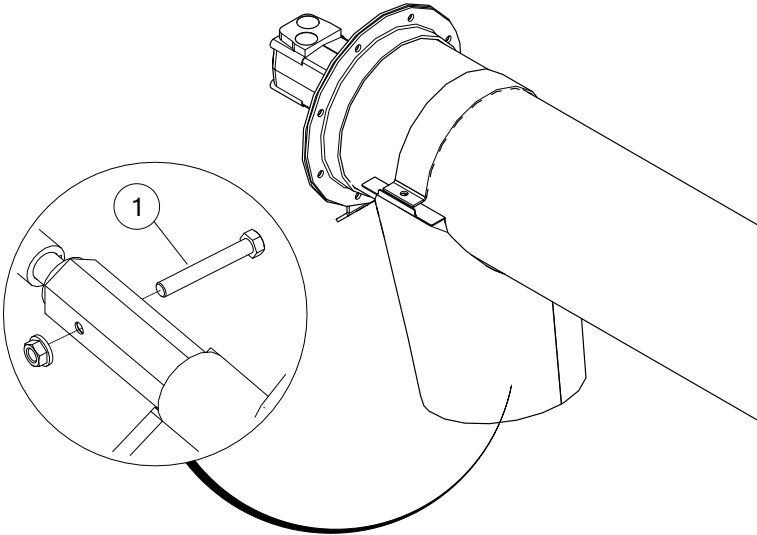

10. Troubleshooting

WARNING Shut down and lock out all power sources before diagnosing any of the causes or attempting any of the solutions below.

In the following section, we have listed some causes and solutions to some of the problems you may encounter.

If you encounter a problem that is difficult to solve, even after having read through this section, please contact your local dealer or distributor. Before you contact them, please have this operation manual and the serial number from your machine ready.

Seed Treating Issues

Problem	Cause	Solution
Seed rates are outside of the expected +/-5%	Conveyor intake wiper is out of adjustment.	Check hopper is installed properly and not bent.
	Cleared conveyor belt is slipping on the drive rollers.	Adjust belt tension and tracking. Ensure side bearing mount plates are free to slide as required.
		Ensure that the cleat travel is not being impeded by an object protruding into the seed travel area.
	Inconsistent feed rate to conveyor.	During operation, ensure that the metering conveyor is full across the cleats by checking the inspection panel on the top of the conveyor.
		Check for blockage of the conveyor intake.
		Ensure that the seed supply gate is fully opened and completely flooding the intake of the conveyor
		Center the conveyor intake under the seed supply opening.
		In a non-typical situation when the conveyor is not being flood fed, like when supplying the conveyor from a truck with a rear opening, the height of the seed in the intake must be the same as the height of the fully deployed and flooded intake hopper.
	Electronics not achieving proper conveyor motor speeds.	Conveyor Drive ratio should be 10:1, adjust if not set correctly.
		Ensure that the Conveyor Correction Factor is set at 1000.

Pump won't prime, pump output is fluctuating	Air leak on intake.	Check treatment container connectors for correct fit, damage or manufacturing problems. Check filter is tight and seal is installed.
	Pump shoe is not fully engaged.	Check that the pump latches are engaged.
	Pump lines are the incorrect length.	Ensure the pump lines are the correct length.
Pump output is inconsistent and outside of the expected +/-5%, or pump is difficult to calibrate	There is an air leak in the fittings on the intake line.	Confirm the location of air leak by removing the tubing from the connector assembly and placing it directly into the product. If calibration is normal, the leak is located in the connector assembly; replace the connector assembly.
		Check that the dry break couplers are fully engaged. Re-engage if required.
		Check the condition of the pump hose, especially inside of the pump and on the intake side of the pump. Ensure it is not cracked or badly distorted.
		Check for loose connections on the intake side of the pump. Tighten loose fittings and hose clamps. Check for cracked fittings or fittings that may not be have been assembled with pipe thread sealant. Replace and reassemble as necessary.
		Ensure the container attached to the pump is free of air leaks, including the connector assembly and drop tube.
		Check for filter seal and that filter body is tight.
	The line is restricted on the intake or output side of the pump.	Check the condition of the pump hose. Ensure it has not collapsed, has become plugged, or is worn-out.
		Check filter and nozzles for plugging.
		If in freezing conditions, check for frozen deposits in the lines. If using a slurried product, check for product settling in the lines.
	Pump is operating at too high of a pressure.	Ensure system is operating at 25 psi or lower. Lower treating parameters, such as treating speed, to reduce system pressure.

		Ensure nozzles and filters are not plugged and hoses are not pinched.
	Pump is operating too slowly.	Some application rates, combined with low seed densities and slow treating speeds can result in slow pump operating speeds. Pump speeds under 60 rpm result in inconsistent flows and are not allowed by the software system. If possible, increase product application rate by diluting in order to increase pump speeds or re-configure the pump.
		Increase treating speed to increase pump speed if operating below 100%.
	Pump is operating too fast.	Viscous (thick) products with high application rates, combined with high seed densities and high treating speeds can result in the pump operating inefficiently. Decrease treating speed to reduce pump speed or re-configure the pump..
	There are calibration errors.	Accepting calibration errors while calibrating a job results in inaccurate pump outputs when the job is run; recalibrate the pumps to eliminate the errors.
		The system signals a calibration error has occurred on the results screen during the calibration procedure.
		Running a job without adjusting for seed flow corrections results in inaccurate pump outputs; recalibrate the pumps to remove the estimated job parameters and replace them with calibrated parameters.
		The system signals it is using estimated values by adding a 9 as a prefix to the Calibration field on the Job Details screen.
	Product condition is inconsistent.	Inadequate mixing may result in product stratification. Ensure that the product has been properly mixed prior to pumping the product with the seed treater.
		Over-mixing can cause some products to foam. Consult with the product manufacturer for proper handling recommendations

	Product is too thick to meter properly.	Dilute product, if possible, to reduce viscosity. Recalibrate as required to ensure accuracy of application.
		Some treatment products change in viscosity with temperature. Ensure calibrations are performed for the conditions at the time of treating.
	Pump is damaged.	Pump may be damaged or warped. Replace if required.
Seed coverage is poor	Nozzles are plugged or damaged.	Check for plugged nozzles, and clean as required.
	Nozzle(s) are misdirected.	Ensure nozzles are oriented correctly and spraying the full seed curtain.
	Nozzle(s) are not creating a spray pattern.	Excessively low pump flow (800 ml/min or lower per nozzle) can result in a poor spray pattern, depending on the treatment type. Increase treating parameters to gain an improved spray pattern. If product application rates are low, consider combining flows or diluting product to increase flow rate through the nozzles.
	Application rates are lower than 300 ml/100 kg of seed.	Consider increasing dilution of treating product or use second pump (if not being utilized) to add water to application.
		Coverage is best for wheat, peas and lentils at application rates of 400 to 600 ml/100kg.
		Coverage is best for barley and oats at application rates of 500 to 700 ml/100kg.
	Application rates are not being obtained.	Check seed delivery and pump rates and ensure they are being met.
		Check condition of pump tubing; replace if there is visible warping or damage.
	Seed condition is affecting coverage.	Dusty seed, dry seed, and frozen seed can affect coverage of many seed treatments.
Treating speed is not optimal for mixer speed.	Running the mixer (auger throttle) too quickly can result insufficient mixing and result in poor coverage.	
Treatment product is too thick.	Thick treatment products may not cover seed adequately. Consult treatment product manufacturer for	

		recommendations and dilute to reduce viscosity if possible
Excessive build-up in application chamber	Seed condition is poor (dusty, dry, etc.).	Dirty or dusty seed will cause build-up. Avoid using excessively dirty or dusty seed.
	Treatment product is too thick.	Thick treatment products can increase build-up. Consult treatment product manufacturer and dilute treatment if possible.
Build-up of treatment on metering conveyor belt	Treatment is flowing when seed is not.	Check for interrupted seed flow. Do not operate the pumps with no seed flow.
	Seed is dusty.	Seed treatment will readily bind to the dust in the seed. Airborne particulates may stick to the conveyor belt.
	Nozzle(s) are misdirected.	Ensure nozzles are oriented correctly and spraying the full seed curtain.
System won't operate at higher conveyor speeds	Pump max. speed limit has been met.	Lower product dilution if possible. Split treatment application to two pumps. Consult with AGI for metering options.
	Insufficient power supply.	Check advanced diagnostics during operation for voltage condition. If low, ensure that the STORM is powered by a dedicated circuit. Extension cords should be 12 gauge or heavier and should not exceed 100 feet in total length. Use a generator that provides a dedicated outlet rated at 240VAC and 30 Amps if power availability is limited.
	Conveyor out of adjustment causing excessive drag.	An improperly adjusted conveyor can increase power requirements. Adjust conveyor.

Conveyor

Problem	Cause	Solution
Conveyor belt slipping.	Conveying belt loose.	Tighten and align belt, see Belt Tension and Belt Alignment in Maintenance.
	Drive roller worn or damaged.	Replace drive roller, see dealer.
Excessive conveyor belt edge fraying.	Belt not aligned.	Align belt, see Belt Alignment in Maintenance.

Problem	Cause	Solution
Conveyor belt loose.	Belt stretches over time.	Re-tension belt, see Belt Tension in Maintenance.
		If belt is fully tensioned, you may need to shorten belt and re-lace, see Belt Relacing in Maintenance.
Grain leaking from conveyor hopper.	Belt not aligned (centered).	Align belt, see Belt Alignment in Maintenance.

Mixer

Problem	Cause	Solution
Poor product flow.	Input speed is too slow.	Increase engine rpm.
	Material is too wet or heavy.	Unloading rates are for dry grain.
	Flighting is worn.	Repair or replace as required.
Excessive noise or vibration. *Remember to follow proper break-in procedures—flighting may run rough until tube is polished. If noise is extreme from outset or continuous after several loads of grain are fed, continue with troubleshooting.	Top drive inadequately engaged.	Check shear pin.
	Broken/distorted flighting sections.	Support seed treater and remove all flighting sections. Check for straightness of flight stubs by rolling across flat concrete section. Straighten stub or replace as necessary. Take care not to bend flighting when reinstalling.
The flighting does not turn.	Seed treater flighting is plugged or obstructed.	Identify and remove obstruction.
	Bearing is seized.	Identify the bearing and replace.
	Shear pin broken.	Replace shear pin.
	Hydraulic issue.	Check hydraulic and electric systems, call dealer for service.
Seed treater flighting is noisy.	Obstruction in the seed treater tube.	Identify and remove obstruction.
	Flighting shaft bolts are loose or damaged.	Tighten or replace bolts.

	Flighting shaft is bent.	Repair or replace flighting shaft.
	Flighting is damaged.	Repair or replace flighting.
	Worn bearing.	Repair or replace bearing.
Shear bolts fail repeatedly.	Incorrect shear bolt type.	Replace with correct part number. STORM shear bolts are specifically designed to provide correct driveline protection.
	Shear bolt hole worn out-of-round.	Frequent use of the incorrect shear bolt size can wear the mounting hole creating a “scissor effect,” which will require replacement of the affected parts.
	Flighting peeled back as a result of plugging.	Occurs when bin has overfilled, or corn spreaders restrict end of discharge. Inspect flighting at discharge end of seed treater. If necessary, replace flighting.
	Driveline failure.	See Maintenance Section.

Mover Kit with Hydraulic Winch Lift

Problem	Cause	Solution
Valve is leaking.	Loose/cracked fittings.	Tighten/replace fittings.
	Worn hose.	Replace hose.
	Valve spools are worn.	Replace valve.
Machine operates slowly.	Oil is hot.	Check oil level and add if required.
	Blockage in hydraulic lines.	Suction hose blocked or kinked.
	Power source is not producing enough oil volume and/or pressure.	Speed up the engine to produce more flow/pressure The power unit may not have enough capacity to operate properly.
	Cushion block needs adjusting.	Adjust valve on cushion block by turning inward 1/8 of a turn at a time, refer to Ram and Travel Speed.
	Filter plugged (if equipped).	Change filter.
Hydraulic winch will not raise seed treater.	Relief valve pressure set too low.	Adjust relief valve pressure, refer to Hydraulic Pressure Adjustment.

	Oil level is too low.	Check oil level.
	Pump is worn out.	Replace pump.
Hydraulic cylinder leaking.	Worn seal.	Replace seal.
Winch coupler spins off (Dutton winch).	Internal winch parts worn.	Replace worn parts.
	Damage or obstruction on tracking.	Check tracking for damage or obstructions.
Seed treater doesn't drive.	Cushion block needs adjusting.	Adjust needle valve by turning clockwise 1/8 of a turn - try and repeat if necessary, refer to Ram and Travel Speed.
Pinion gear slipping or binding.	Pinion gear not adjusted properly.	Adjust the pinion gear. See Pinion Gear Adjustment.

Drive

Problem	Cause	Solution
Drive belts jumping off pulleys.	Motor misaligned.	Ensure drive and driven pulleys are correctly aligned.
	Belts mismatched.	Check Specifications section for correct belt sizes and only replace in pairs.
	Belt tension inadequate.	Adjust tension.

11. Appendix

11.1. Test Weight Procedure

Follow this procedure to achieve highly accurate seed density and highly accurate seed treatment application.

Repeat this procedure five times for best accuracy. Eliminate the highest and lowest value and average the three middle measurements for best results.

1. Level then power on the scale.
2. Place the (0.5L) on the scale then tare the scale.
3. Fill the cup (0.5L) to overflowing with the grain to be tested.
4. Ensure the slide is inserted into the cox funnel, then pour the contents of the cup (0.5L) into the cox funnel.
5. Place the cup (0.5L) on the catch pan for the overflow.

Note

Ensure the catch pan is on a level surface.

6. Position the cox funnel on top of the cup (0.5L) so that the notched legs of the funnel fit securely on the cup's rim.
7. Remove the slide of the cox funnel quickly, allowing the contents of the funnel to empty into the cup (0.5L).
8. Carefully remove the cox funnel from the cup's rim taking care not to disturb the grain.

Note

Jarring of the cup may result in the compaction of the grain which can lead to inaccurate results.

9. Place the hardwood striker on the rim of the cup (0.5L) and, using three zigzag motions, remove the excess grain in the cup.
10. Place the cup (0.5L) on the scale; the displayed units in grams in your seed density.

Note

See www.labtronics.ca for further information, including test weight conversion charts.

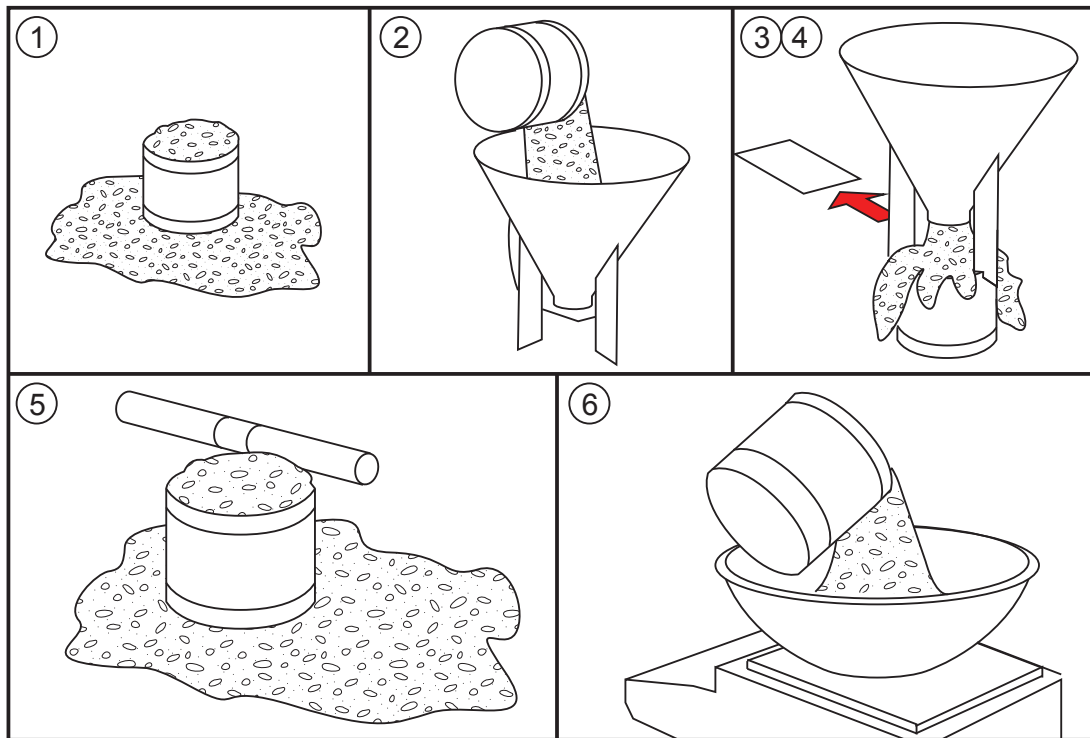
Figure 72. Test Weight Procedure Steps

11.2. Updating System Software

To Ensure your STORM is operating at optimum levels, always install the most up-to-date software found on the "Downloading Software" tab or Of the www.stormtreaters.com website /owner centre

The STORM control uses a USB Flash Drive to transfer treating history and to install new software. It is located under the USB port weather cap on the control box of your STORM.

Steps to Installing New Software

1. Ensure that important treating records and job information has been removed from the STORM controls. Updating the software will erase all data stored in the controls. To do this follow the instructions on the "Recording Treating History and Job Information" tab.
2. Format the USB flash drive by following the instructions on the "Formatting the USB Flash Drive" tab. Formatting will erase the entire contents of the USB flash drive.
3. Download the software and extract it to the USB flash drive by following the directions on the "Software Download Instructions" tab.
4. Install the software onto the STORM controls by following the instructions on the "Software Installation Instructions" tab.

If you are having issues with the download and installation process, please contact STORM Customer Service at 1.855.662.6609 or storm@aggrowth.com.

11.2.1 Treating History & Job Information

Important

Installing new software will erase all treating history and job information stored in the controls. This step does not apply to new users who have not set up a treating history.

Before Updating the Software

1. Download the history from the Touchscreen onto the USB. Please consult the operator manual for your STORM model for step by step instructions. Instruction manuals can be found on the Literature tab above.
2. Record job parameters from "Jobs" on HMI.
3. Record total lifetime use.
4. Transfer history files to the computer.

If you are having issues with the download and installation process, please contact STORM Customer Service at 1-855-662-6609 or storm@aggrowth.com.

11.2.2 Formatting a USB

How to Format a USB Flash Drive Using a PC

1. Put your USB in the USB port on your computer.
2. Click the start-up icon on the lower left side of the screen.
3. Click on "Computer" on the right side.
4. Right click on "Removable Disk" or the name given to your USB.
5. Click "Format". Ensure that the file system type is selected as fat32 and that quick format has been selected for the formatting option.
6. Click "Start".

How to Format a USB Flash Drive Using a Mac

1. Insert USB flash drive into the USB port on the computer.
2. Click "Finder" -> "Applications" -> "Utilities" -> "Disk Utility".
3. On the left side, click your USB. Choose the root folder, and not the indented folder below it.
4. Click "Erase".
5. Click "Erase" again.

Note

Formatting can take a few seconds or a few minutes.

If you are having issues with the download and installation process, please contact STORM Customer Service at 1-855-662-6609 or storm@aggrowth.com.

11.2.3 Downloading Software

Steps to Downloading the Software

1. The STORM USB Flash Drive is located under the USB port weather cap on the control box of your STORM unit.

2. Once you have located the USB, insert it the USB port on your computer. The flash drive may appear on your desktop as removable drive.
3. If you have both the STORM FX and STORM PRO, please make sure you downloading the correct files for the model you will be updating.
4. Click the "Downloading Software" tab for the latest software version. Both .exe and .zip files are available for your convenience. Although the .exe file is recommended, some firewalls may prevent the file from being downloaded to your computer. We assure you that the files are virus free and safe for download. If you are not able to download the .exe file, a.zip file is available. Please note that with the .zip version, you will need to extract the data before saving it to your USB. This requires .zip software. Visit www.zipeg.com for more details.
5. When you click the software version of your choice, your browser will automatically download the file to your computer. Typically, the default folder will be "Downloads". You can create and select an alternate folder on your desktop labeled "STORM Software" for easy access.
6. If you have downloaded the .zip file you must first unpack the file and then save the contents to the USB. This requires .zip software. Visit www.zipeg.com for more details. You should have nine items on the USB before ejecting.
7. If you have downloaded the .exe file, please double click on the file, choose run, update the destination folder to your removable drive using the browse button and finally press the extract button. Please verify you have nine items on your USB before ejecting.

Note

Please ensure that the software file is not located inside another folder or with other files you may have on the flash drive.

If you are having issues with the download and installation process, please contact STORM Customer Service at 1-855-662-6609 or storm@aggrowth.com.

11.2.4 Installing Software

Important

Updating software will erase all job information. Manually write down recipes and other important information before completing the steps below.

1. Power up the STORM controls. The unit will automatically initialize the software. When complete, the main screen will be displayed. Plug the USB into the USB port .
2. The software update will start automatically. When asked "Do you want to install a new project from the USB drive?", Select "Yes" and the software will begin loading.
3. When the message "Installation Complete" appears, press "Restart" at the bottom of the screen. The unit will initialize the software again.
4. When the main screen is displayed on the STORM Classic and STORM FX, unplug the control box for 30 seconds. Power up the control box again and make sure the software loads properly. The main screen should be displayed if it has loaded properly.
5. **DO NOT REMOVE THE USB** - leave in and cover with the weather cap.

If you are having issues with the download and installation process, please contact STORM Customer Service at 1-855-662-6609 or storm@aggrowth.com.

12. Specifications

CAPACITY	
Seed Flow	15 to 30 bu/min (900 to 1,800 lbs/min at 60 lbs/bu)
Treatment Application Rate	10 to 1200 ml/100kg*
Treatment Application Coverage Accuracy	+/- 5% (typical)
Tube Size of Mixer	10" (254 mm)
DIMENSIONS	
Transport	Length 50'2" (15.3 m)
	Width 8' (2.43 m)
	Height 10'11" (3.33 m)
Discharge Clearance	Min 11'10" (3.62 m)
	Max 15'8" (4.78 m)
TIRES	
Size/Type	15" Radial
Inflation Pressure	20-24 PSI (137-165 kPa)
WEIGHT	
Hitch Tongue Weight	880 lb (400 kg)
Total Weight	3640 lb (1650 kg)
POWER REQUIREMENTS	
Gas Engine	32 HP
Control System Power	240VAC X 30A
PART SPECIFICATIONS	
Hitch Pin	1" dia. 3" effective length min.
Treating Hoses	9-1/2" (241 mm) IP26 Masterflex Norprene Food
Chemical Filter	30 Mesh
Fuel Tank Capacity	14 US Gal (53 L)
Hydraulic System Capacity	40 L (Universal Tractor Fluid)
Shear Pin (top end of flighting)	3/8" x 2-1/2" hex bolt (Grade 8) and 3/8" locknut

* Rates are job specific, and may require adjustments including dilution, splitting between pumps, or changing of treating speed to accomplish.

13. STORM Warranty

Ag Growth International (AGI) warrants products of its manufacture against defects in materials or workmanship under normal and reasonable use for a period of 18 months after date of delivery to the original purchaser.

Our obligation under this warranty is limited to repairing, replacing, or refunding defective part or parts which shall be returned to a distributor or a dealer of our Company, or to our factory, with transportation charges prepaid. This warranty does not obligate AGI to bear the cost of labor in replacing defective parts. Any defects must be reported to the Company before the end of the one year period.

This warranty shall not apply to equipment which has been altered, improperly assembled, improperly maintained, or improperly repaired so as to adversely affect its performance. AGI makes no express warranty of any character with respect to parts not of its manufacture.

The foregoing is in lieu of all other warranties, expressed or implied, including any warranties that extend beyond the description of the product, and the IMPLIED WARRANTY of MERCHANTABILITY is expressly excluded.

AGI **STORM**

Shipping: 201 Industrial Drive, Swift Current, Saskatchewan S9H 5R4, CANADA

Mailing: Box 1750, Swift Current, Saskatchewan S9H 4J8, CANADA

Toll-Free: (877) 667-7421 (Canada & USA)

Phone: (306) 773-7779

Fax: (306) 778-2524

Website: www.aggrowth.com

©Ag Growth International Inc. 2021

Printed in Canada

If you have any comments or questions on this manual, or find an error, email us at comments@aggrowth.com.
Please include the part number listed on the cover page in your message.